



ULTIMATE

The [^] ABO Study Guide

Version 6.23

This document is public domain and may be reprinted as-is and distributed without prior authorization. Documents must be shared and printed in its entirety and may not be altered in any way.

Looking to pass the basic written ABO? For those of you with great study skills and some optical background this free guide might just do the trick!

However, most people find that working through the complete OpticianWorks.com program is the way to go. To the best of our knowledge no one has ever really worked through the entire program and not passed the ABO. In fact, it would be almost impossible to do so.

The complete program is found at: OpticianWorks.com Be sure to read the complete FAQ.

Be sure to visit the free YouTube channel: [LaramyK OpticianWorks On YouTube](https://www.youtube.com/channel/UCqK1m1m1m1m1m1m1m1m1m1m)

It is chock full of videos covering every one of the important topics in detailed, easy to follow examples.

Don't forget us when it's time to choose a lab. Visit us at: LaramyK.com

This document is completely free to print, use, share, and distribute.

To be sure you have the latest version visit us at: OpticianWorks.com under Free Training & More. The American Board of Opticianry (ABO) does not endorse any test preparation program or study materials.

The ABO is the minimum required knowledge to start a career as an optician.

The ABO does NOT prepare you for the actual work you will be doing as an optician. The ABO does NOT cover; sales, specialty eyewear, insurance or vision care plans, business management, contact lenses, finishing, lab relations, repairs or order processing and more.

OpticianWorks.com does!

*** This guide will be 90+ pages to print and is best printed in color.**

How to Pass the ABO:

The ABO is based on concepts. To pass the ABO you need to grasp the concepts. The concepts are quite basic, and you will pass the exam if you apply:

Memorization: Good old-fashioned memorization. Study until you have the concepts memorized. Use flashcards, quiz sessions and study.

Practice: Work the examples given five, ten, fifteen times or until you can see the patterns.

Visualization: Close your eyes and picture the concepts in your mind. Picture them in practice and in three dimensions. Practice it!

Drawing: You are given scrap paper for a reason. USE IT! If you do not draw the prism questions out, you will not get the questions right.

The ABO is a multiple-choice exam. If you take your time, you will be able to determine the correct answer every time by the process of elimination.

Chapter 1: Ocular Anatomy

<i>The Structure of the Eye</i>	6
<i>The Oculomotor Muscles of the Eye</i>	11
<i>Refractive Errors</i>	12

Chapter 2: Basic Optical Principles

<i>Light and the Electromagnetic Spectrum</i>	18
<i>Refraction</i>	18
<i>The Index of Refraction "n"</i>	19
<i>Diopter/Prism Diopter</i>	19
<i>Lenses as Prisms</i>	20
<i>Lens Power and Lens Power Formulas</i>	22

Chapter 3: Lens Form

<i>Sphere</i>	24
<i>Cylinder</i>	24
<i>Axis</i>	25
<i>Aspheric Lens Design</i>	26
<i>Flat Transposition</i>	26
<i>The Optical Cross</i>	27
<i>Prism</i>	29
<i>Optical Center Verses Major Reference Point</i>	29
<i>Working with Prism Prentice's Formula</i>	30
<i>Compounding Prism - Canceling Prism</i>	30
<i>Prism Power & Meridian</i>	30

Chapter 4: Lens Options

<i>Lens Materials</i>	34
<i>Lens Material & Thickness</i>	35
<i>AR or Non-Glare Coatings</i>	36
<i>Photochromic: (Changeable Tint Lenses)</i>	36
<i>Polarization</i>	36
<i>Tinting</i>	37
<i>Multifocals</i>	38
<i>Progressives</i>	40
<i>Slab Off</i>	41

Chapter 5: The Written Prescription

<i>Primary prescription information explained</i>	42
<i>Conversion of a prescription with an add power provided to single vision readers</i>	44

Chapter 6: Frames

<i>How Frames Are Measured</i>	46
<i>The Parts of an Eyeglass Frame</i>	47
<i>Frame Materials</i>	50
<i>Verifying frame and lens parameters and other physical characteristics</i>	52
<i>Standard Alignment</i>	56
<i>Measuring</i>	60
<i>Applying Product Knowledge</i>	64
<i>Dispensing a complete pair of glasses</i>	66
<i>Trouble shooting</i>	67

Chapter 7: Tools

<i>The Lensmeter</i>	68
<i>How to focus a lensometer for individual use</i>	70
<i>Lens Clock</i>	73
<i>Ophthalmic Tools, Instruments & Equipment</i>	74
<i>Verification</i>	76
<i>Verifying Prescribed Prism</i>	79

Chapter 8: Regulations & Standards

Chapter 1: Ocular Anatomy

The Structure of the Eye

The eye is made up of three layers:

1. The fibrous tunic, which consists of the sclera and the cornea.
2. The vascular tunic consists of the iris, the choroid and the ciliary body and is responsible for nourishment.
3. The nervous tunic which is the inner layer of photoreceptors and neurons which consists of the retina.

The nervous tunic or neural layer contains the special photo (light) receptors known as rods and cones.

- Rods do not discriminate between different colors of light. The rods let us see at twilight and in dimly lit rooms.
- Cones do discriminate colors. Cones require brighter light to function than rods do.

There are approximately 120 million rods spread towards the outside of the retina and about 6 million cones concentrated near the center of the macula. The highest concentration of cones is found at the fovea which is the center of the macula. The macula is where light will focus in a healthy eye.

The point where the optic nerve enters the eye is known as the optic disc. The optic disc does not contain receptor cells, so it is sometimes called the “blind spot”.

The eye also contains three fluid-filled chambers:

1. The anterior chamber between the cornea and the iris
2. The posterior chamber between the iris and the lens

The anterior and posterior chambers contain a fluid called aqueous humor. Aqueous humor is watery fluid produced by the ciliary body. It maintains pressure (called intraocular pressure or IOP) and provides nutrients to the lens and cornea. Aqueous humor is continually drained from the eye through the Canal of Schlemm.

3. The vitreous chamber is found between the retina and the lens and is filled with a thicker gel-like substance called vitreous humor which maintains the shape of the eye

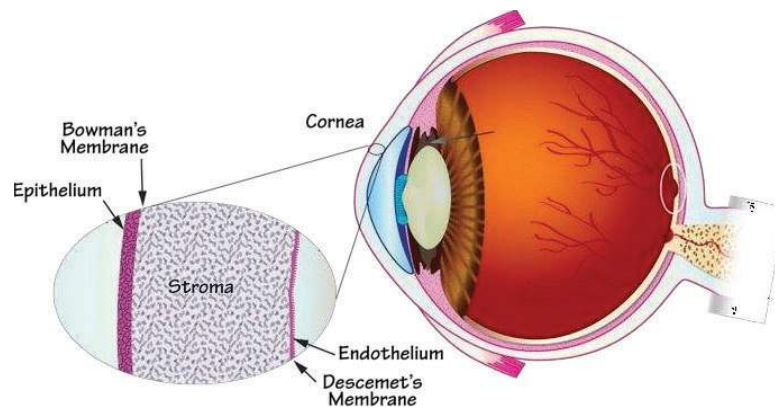
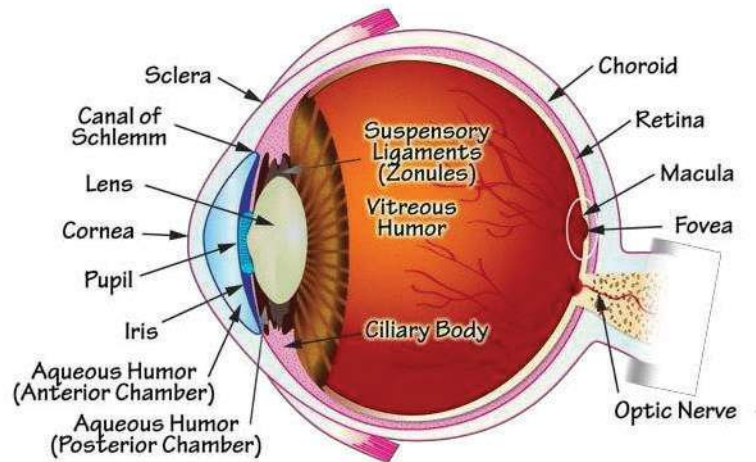

Light enters the eye through the transparent, dome shaped cornea.

The cornea consists of five distinct layers:

1. The outer most layer is the epithelium which rests on Bowman's membrane
2. The next layer, which acts as a protective barrier, is Bowman's Membrane
3. The stroma which is between the two membranes makes up 90% of the thickness of the cornea
4. Descemet's Membrane separates the stroma and the endothelium
5. The inner most layer, the endothelium, removes water from cornea, helping to keep the cornea clear

Memory Hint: B comes before D and think "end" for endothelium.

From the cornea, light passes through the pupil. The amount of light allowed through the pupil is controlled by the iris, the colored part of the eye.

The iris has two muscles:

1. The **dilator muscle** which opens the iris allowing more light in
2. The **sphincter muscle** which closes the iris

The iris has the ability to change the pupil size from 2 millimeters to 8 millimeters.

Just behind the pupil is the **crystalline lens**. The purpose of the lens is to focus light on the retina. The process of focusing on objects based on their distance is called **accommodation**. The closer an object is to the eye the more power is required of the crystalline lens to focus the image on the retina. The lens achieves accommodation with the help of the **ciliary body** which surrounds the lens. The ciliary body is attached to lens via fibrous strands called **zonules**.

When the ciliary body contracts, the zonules relax allowing the lens to thicken, adding power, allowing the eye to focus up close. When the ciliary body relaxes, the zonules contract, drawing the lens outward, making the lens thinner, and allowing the eye to focus at a distance.

No time like now to start memorizing some things.

Give this a try for practice:

The Layers of the Cornea

Match

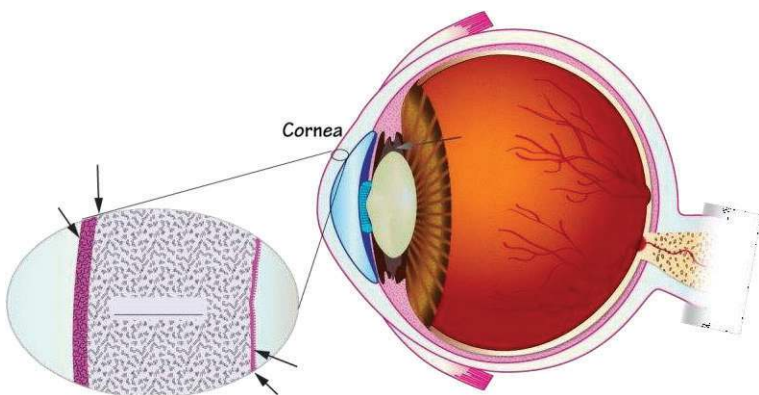

- A Stroma
- B Endothelium
- C Epithelium
- D Descemet's Membrane
- E Bowman's Membrane

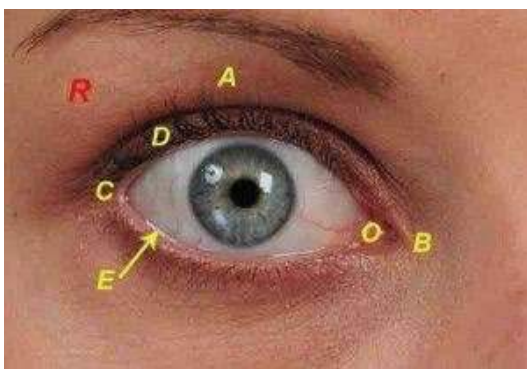
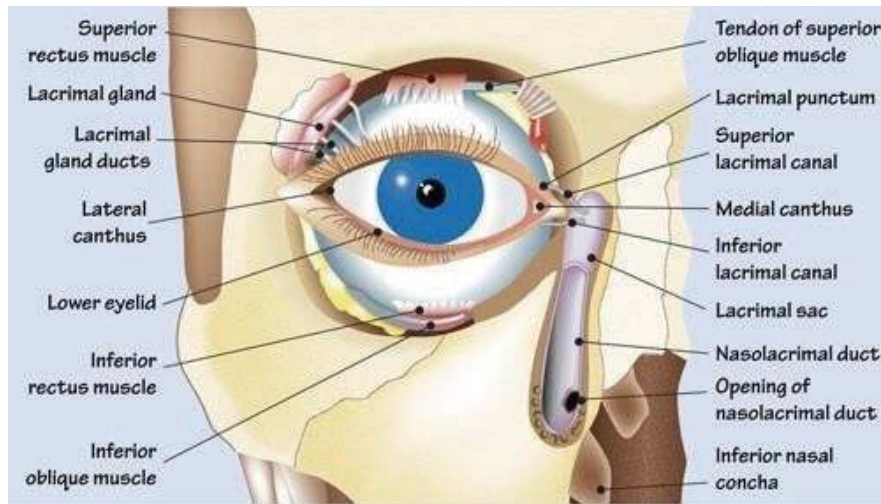

A - Palpebrae: Another term for the eyelid.

B - Medial Canthus: This is the point where the upper and lower eyelids meet near the nose. In layman terms, "the corner of your eye."

C - Lateral Canthus: This is the point where the upper and lower eyelids meet towards your ear.

D - Eyelashes: Strong hairs that run along the upper and lower palpebral margins. They are there to filter debris from entering the eye.

E - Meibomian Glands: Located along the inner margin of the eyelids the glands secrete a liquid that keeps the eyelids from sticking together. These secretions make up part of the tear film.



O - Fornix: (NOT REALLY VISIBLE IN IMAGE): Actual location is behind the eyelid or palpebra and along the sclera. It is where the two layers of the conjunctiva meet and join.

R - Lacrimal Gland: INSIDE THE ORBIT OF THE EYE The gland that produces the bulk of the tears. It is located above the lateral canthus in a depression in the bone that surrounds the eye.

N - Lacrimal Puncta: (NOT REALLY VISIBLE IN IMAGE): Small openings (pores) located at the medial canthus that allow the accumulated tears to drain off the eye. The tears drain through the nasal cavity which is why when you cry your nose runs!

- Lacrimal Canals - The path the tears take from the eye to the lacrimal sac and then to the nasal passage.
- Lacrimal Caruncle - Located at the medial canthus the lacrimal caruncle also produces a liquid that soothes and lubricates the eye.
- These secretions combine with those from the Meibomian glands to make up the eyes tear film.

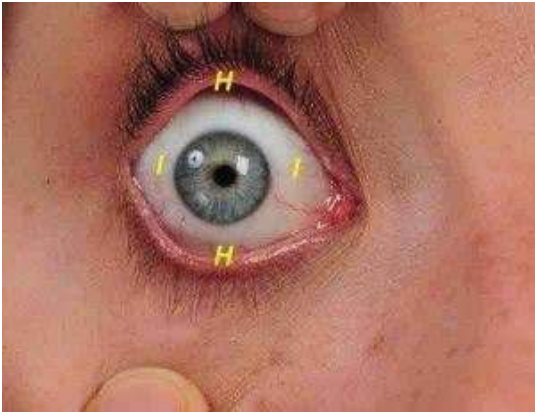

J - Cornea: The clear lens or structure that covers the iris or the colored part of the eye. The cornea is the first major structure that refracts light as it enters the eye. It has no blood supply and gets all of its oxygen directly from the air.

K - Pupil: The opening created by the iris changing size.

L - Sclera: In layman terms, "the whites of your eyes." The sclera is a thick, tough and fibrous layer that provides the structure of the entire eyeball.

M - Limbus: Where the cornea blends into the sclera.

Q - Iris: The colored area under the cornea that opens and closes to regulate light entering the eye.

H - Palpebral Conjunctiva: The layer that covers the eyelids.

I - Ocular or Bulbar Conjunctiva: The layer that covers the exposed portions of the eye.

Your Turn - See if you can label the following.

Eye Anatomy

Name the parts

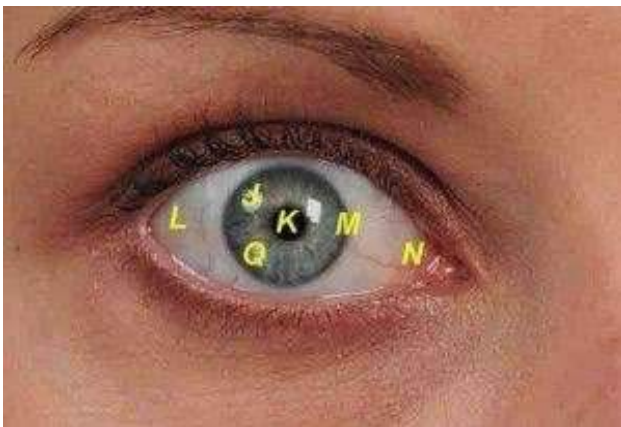

J
K
L
M
N
Q

The Oculomotor Muscles of the Eye

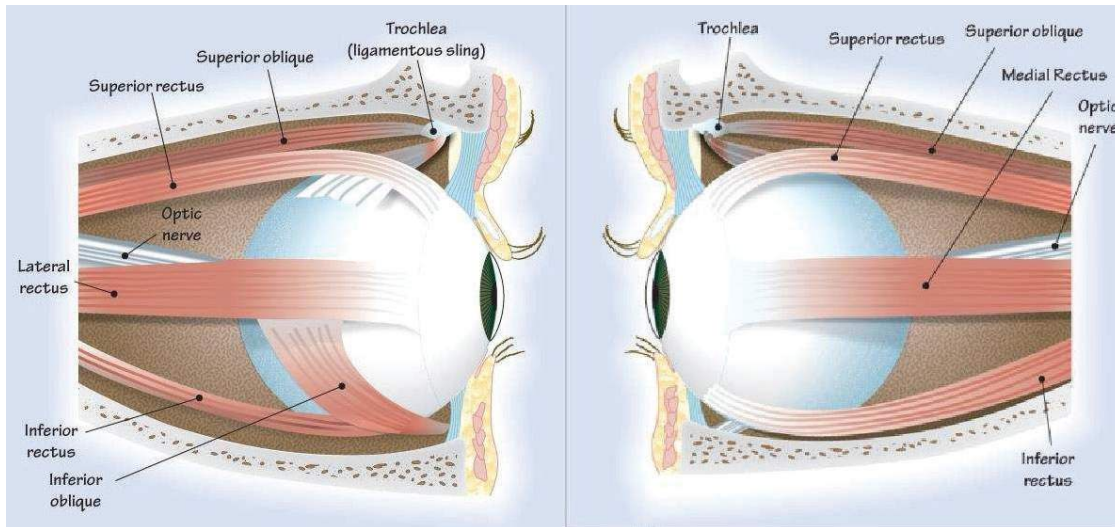

Lateral Rectus: Rotates eye laterally or out towards the ear. Attaches directly to the side of the eye and runs straight back.

Superior Rectus: Eye looks up. Attaches directly to the top of the eye and runs straight back.

Medial Rectus: Rotates eye medially or in towards the nose. Attaches directly to the side of the eye and runs straight back.

Inferior Rectus: Eye looks down. Attaches directly to bottom of the eye and runs straight back.

Inferior Oblique: Eye rolls, looks up and to the side. It attaches along the lateral side of the eye and runs under the eye passing over the inferior rectus and attaches medially.

Superior Oblique: Eye rolls, looks down and to the side. Attaches under the superior rectus, passes through a bony spur known as the Trochlea, and then follow the path of the superior rectus. The raised attachment point provides the muscle the ability to give the eye rotation.

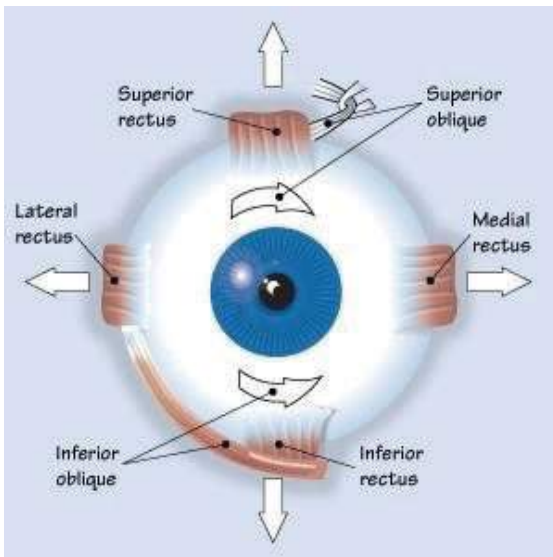

Can you find the following muscles?

The Oculomotor Muscles

Match

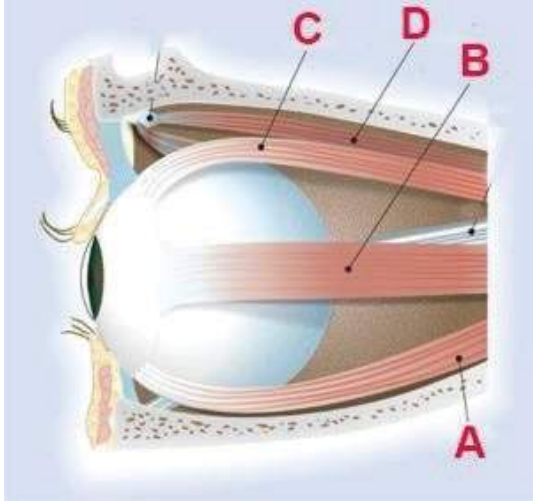

- A
- B
- C
- D

Do you know the pre-screen exam procedures & instruments? Want to learn all the common medical conditions that you will see? Learn more! Be more! Earn more! Be happier! The ABO is only the beginning! Join us at: OpticianWorks.com

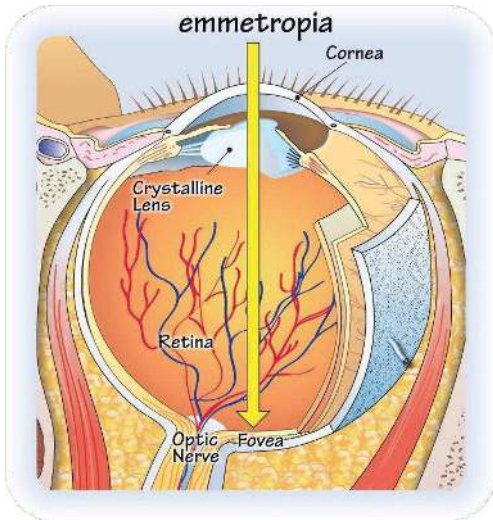

The Emmetropic Eye: Notice that in the emmetropic eye all the rays of light entering the eye all focus on the retina right where they need to be to provide crisp sight without the need of corrective lenses.

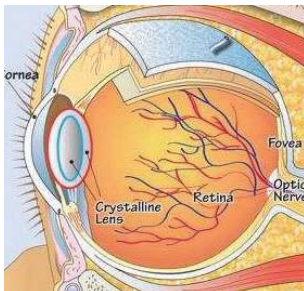

The Eight Common Refractive Errors of the Human Eye

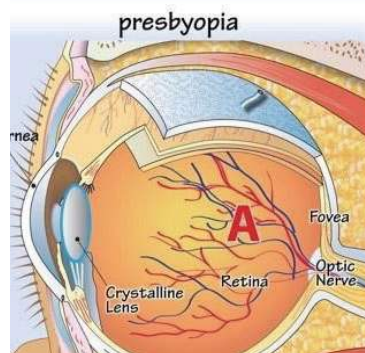
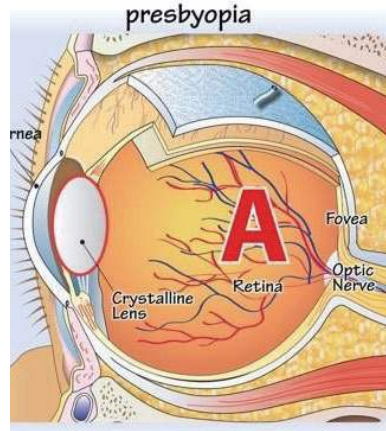

Presbyopia: Presbyopia makes us unable to read fine print, thread a needle, or do fine work without the aid of magnification.

Presbyopia is when the crystalline lens can no longer change shape and provide accommodation. It remains in the flatter less plus shape shown in blue.

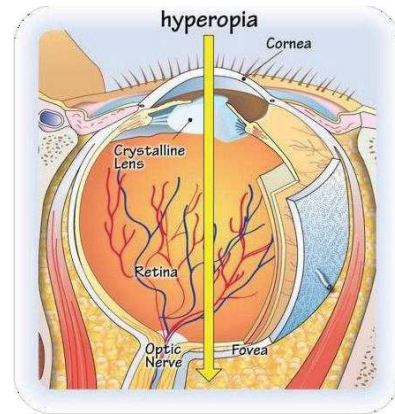
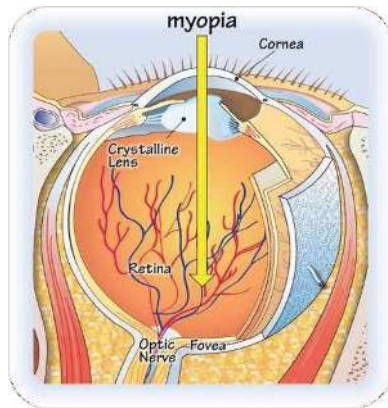

Simple Myopia: Simple because all the rays of light entering the eye focus at the same spot, it is the wrong spot, but they all meet at the same place. The retina is further back from the cornea than in an emmetropic eye, so the rays fail to reach the back of the eye and the retina.

Persons with myopia are nearsighted; they are capable of seeing things at “near” distances, or up very close to their eyes. They can read fine print, thread a needle, and work with tiny objects. They cannot see a street sign down the road or a bird high in a tree, without correction.

Myopia is corrected with minus lenses.

It is easy to remember: Just think my-opia and mi-nus lenses.

A prescription for a person with simple myopia would be written like one of these examples:

- 1.00 Sphere
- 2.50 Sphere

Simple Hyperopia: In simple hyperopia all the rays of light entering the eye focus at the same spot, it is the wrong spot, but they all meet at the same place. The retina is further forward toward than the cornea in an emmetropic eye, so the rays are trying to focus on an imaginary point beyond the back of the eye.

Persons with simple hyperopia are farsighted; they are capable of seeing things in the distance or far off. They can easily see a street sign half a mile down the road and a bird high up in a tree. They cannot see fine print, thread a needle, or do detail work without correction. Hyperopia is corrected using plus lenses.

A prescription for a person with simple hyperopia would be written like one of these examples:

- +1.00 Sphere
- +2.50 Sphere

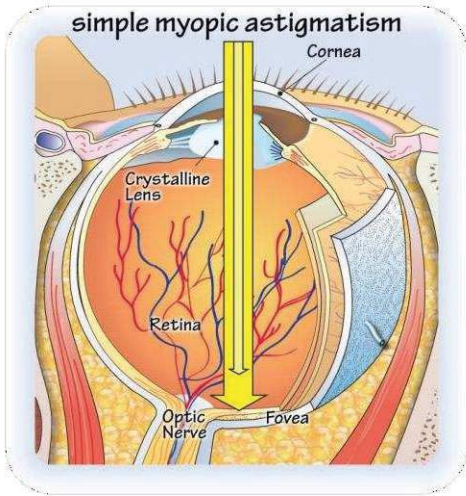

Simple Myopic Astigmatism: In simple myopic astigmatism some of the rays of light entering the eye fall short of their intended spot on the retina, but some fall directly on the fovea, where they need to be.

Simple myopic astigmatism is corrected using toric lenses. One focus point of the eyeglass lens will provide no correction, or have 0.00 power, for those rays that are falling where they are needed. Another focus point of the lens will have power for the rays that need to be redirected to the correct place on the retina.

A prescription for a person with simple myopic astigmatism would look like one of these examples:

- 0.00 -0.50 X 45
- 0.50 + 0.50 X 135
- 0.00 -2.00 X 130
- 2.00 +2.00 X 40

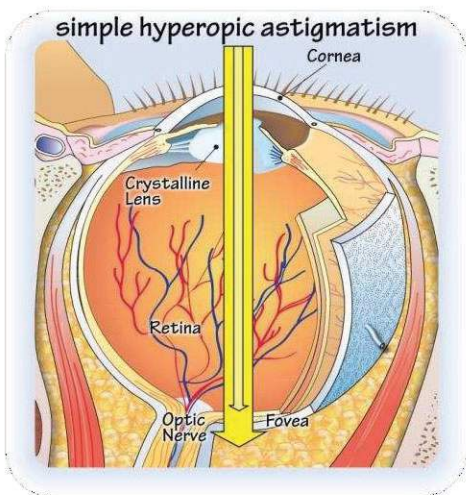

Simple Hyperopic Astigmatism: In simple hyperopic astigmatism some of the rays of light entering the eye focus on a spot beyond the retina, but some fall directly on the fovea where they need to be.

Simple hyperopic astigmatism is corrected using toric or sphero-cylinder lenses. One focus point of the lens will provide no correction, or have 0.00 power, for those rays which fall where they should. Another focus point of the lens will have power for the rays that need to be redirected to the correct place on the retina.

A prescription for a person with a simple hyperopic astigmatism would look like one of these examples:

- +1.50 -1.50 X 45
- 0.00 +1.50 X135
- +2.50 -2.50 X 130
- 0.00 +2.50 X 40

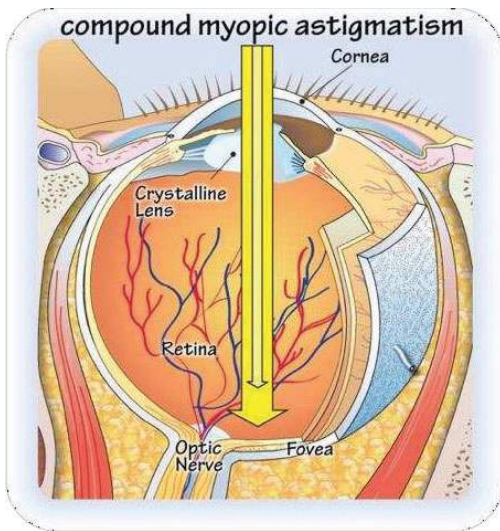

Compound Myopic Astigmatism: This condition is no longer simple, because the rays of light entering the eye do not all meet at the same place. They all fall short of their intended spot on the retina, but some fall closer than others.

Depending on the degree of astigmatism (the degree to which the cornea is misshapen) the individual may see objects as bent or distorted in shape as well as blurred.

A prescription for a person with a compound myopic astigmatism would look like one of these examples:

- 1.00 -0.50 X 45
- 1.50 +0.50 X 135
- 2.50 -2.00 X 130
- 4.50 + 2.00 X 45

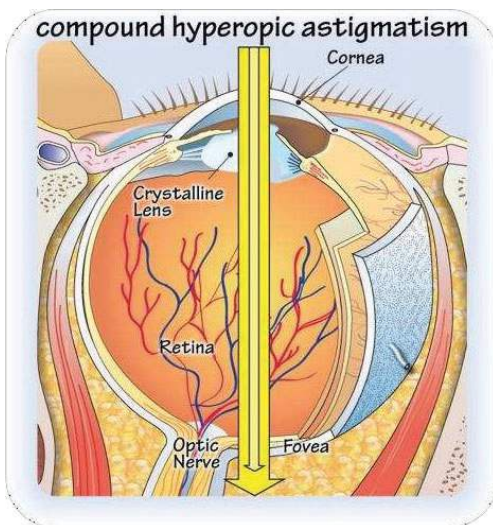

Compound Hyperopic Astigmatism: This condition is no longer simple, because not all the rays of light entering the eye meet at

the same place. They all focus on a spot beyond the retina, but some come closer to the fovea than others.

Depending on the degree of astigmatism (the degree to which the cornea is misshapen) the individual may see objects as bent or distorted in shape as well as blurred.

A prescription for a person with a compound hyperopic astigmatism would look like one of these examples:

- +1.00 -0.50 X 45
- +0.50 +0.50 X 135
- +2.50 -2.00 X 130
- +0.50 +2.00 X 40

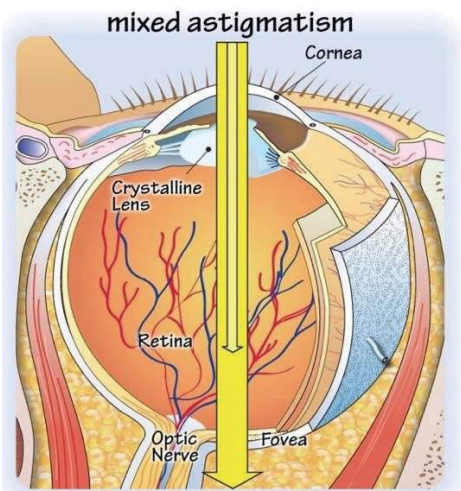

Mixed Astigmatism: In the eye with mixed astigmatism some rays fall ahead of the retina while others try to focus on a spot beyond the retina. People with mixed astigmatism are neither nearsighted nor farsighted, but instead will have poor vision in all areas.

A prescription for a person with a mixed astigmatism would look like one of these examples:

- +1.00 -2.00 X 45
- 1.00 +2.00 X 135
- +2.00 -2.25 X 67
- 0.25 + 2.25 X 157

Can you match the name with the correct image?

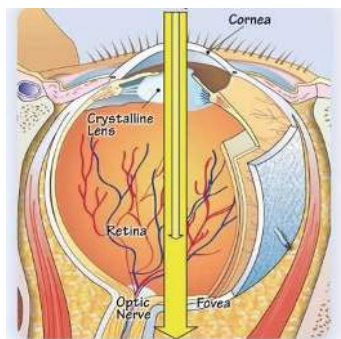

A

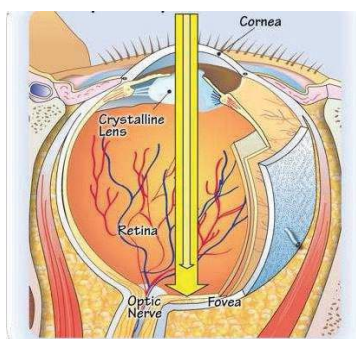

B

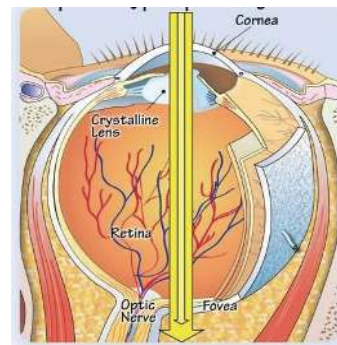

C

Simple myopic astigmatism _____

Mixed astigmatism _____

Compound hyperopic astigmatism _____

Chapter 2: Basic Optical Principles

Light and the Electromagnetic Spectrum

Note: The principles provided here are in the very simplest terms possible. The physics of light and lenses is far more complex than the generalized presentation here.

Every second of every day we are bombarded with and surrounded by electromagnetic radiation. Some bounces off of our bodies, some passes through us, and some we absorb, but most goes undetected and unperceived.

A tiny fraction of electromagnetic radiation is visible to the human eye. Only the portion of the electromagnetic spectrum that makes it through our corneas and is absorbed by our retinas is perceived as color and light.

Light is a form of radiant energy. It acts as both a particle and a wave. It travels at the fastest known speed in our universe which is 186,000 miles per second.

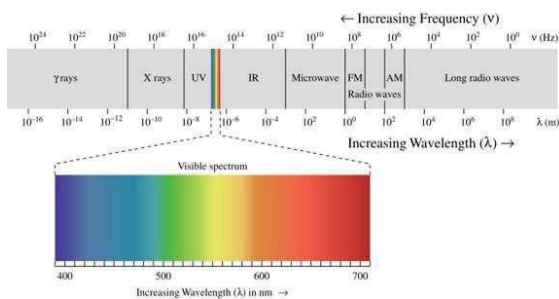

Often expressed in nanometers (nm) or one billionth of a meter, the wavelengths of the visible spectrum lie between 400nm and 700nm. Red light is at the longer end of the spectrum and violet light at the shorter end.

A common acronym used to remember the order of colors in the visible spectrum is ROY G BIV (red, orange, yellow, green, blue, indigo, and violet).

Just below 400nm lies ultraviolet (UV), while just above 750nm lies infrared

(IR). Refraction

Light waves travel through transparent media (water, lenses, glass) at different speeds. As light moves from one transparent medium to another, at any angle other than perpendicular to the material surface, the change in speed will also result in a change in direction.

This change in direction is called refraction. The greater the change in speed, the greater the magnitude of refraction becomes. Refraction is principle that allows the creation of optical lenses that alter the path or focus of light.



The change of speed and direction is why objects appear out of place like the spoon in the glass.

The Index of Refraction “n”

“n” is the notation for index of refraction. The index of refraction tells us how much a given material will slow down and change the direction of a ray of light passing through it. The higher the index or “n” the thinner a lens can be and produce the same power.

Common index numbers include, 1.498, 1.523, 1.586, 1.60, 1.67, and 1.74.

It is a scientific absolute that the higher the index of refraction, the thinner a lens can be and still produce the same diopter value.

- A lens with an index of refraction of 1.74 and a power of – 6.00 will be thinner than a lens with an index of refraction of 1.53 with the same power of – 6.00.

Dr. Mark Roth OD 235 Ramapo Valley Road Oakland, NJ 07366 201-337-4058				
DEA License # 67532				
NPI # 870				
Patient: Heidi Klum				
	Sphere	Cylinder	Axis	Prism
OD	-1.25	-0.50	90	
OS	-2.25	-1.25	95	
Add				
Notes:				
10/12/2018				
Signature of provider: <u> Mark Roth OD </u>				

The numbers (2.25, 1.25, 0.50) you see on the prescription example represent diopters. Diopters are a unit of measure not unlike an inch, pound, or mile.

Technically a diopter is a way of expressing where the rays of light that are passing through a lens (two prisms) will fall.

The formula for a diopter is this:

$$D = 1/f$$

When D is diopter, and f is the focal length of a lens in meters.

So if I know that a lens has a focal length of 0.50 meters $1/0.50 = 2$ My lens diopter power is 2.00

The formula can also work the other way so that f is equal to $1/D$ $F = 1/D$

So if I know that a lens is 2.00 diopters $1/2.00 = 0.50$ My lens focal length will be 0.50 or half a meter.

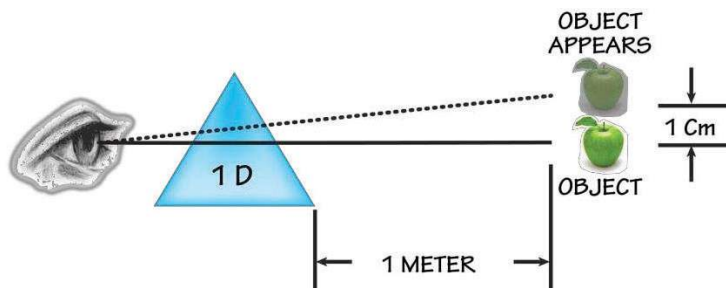

Prism diopter: A prism of 1.00D produces the appearance of a 1 centimeter shift in position of an object being viewed at a distance of 1 meter.

It's Jeopardy Time! Answer the following-

186,000 Miles per second _____

1.74 _____

$D = 1/f$ _____

400 to 700 _____

A What is the formula for diopter?

B What is the speed of light?

C What is the range of visible light in nanometers?

D What is an example of an index of refraction?

Lenses as Prisms

At their heart, all ophthalmic lenses are two prisms, stacked either apex to apex, or base to base. A plus lens is simply two prisms, stacked base to base (the flat bottom of a prism). A minus lens is simply two prisms, stacked apex to apex (the pointy top of a prism). The term used for modern optical lenses is, meniscus lens, because its shape is like the shape of a meniscus moon.

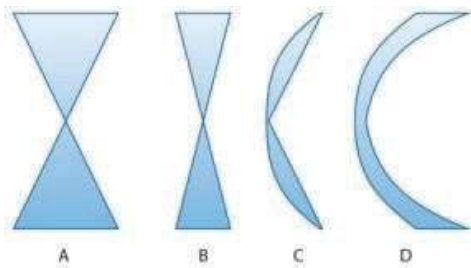

- A = Exaggerated two prisms stacked apex to apex
- B = Two prisms stacked apex to apex
- C = Two prisms stacked apex to apex with a front base curve
- D = A complete meniscus ophthalmic lens with front base curve and corrected back curve

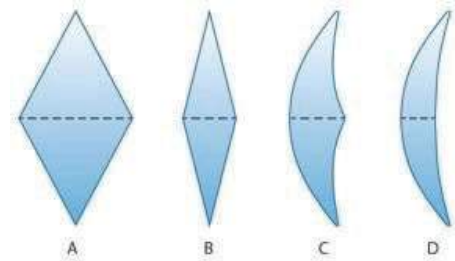

- A = Exaggerated two prisms stacked base to base
- B = Two prisms stacked base to base
- C = Two prisms stacked base to base with a front base curve
- D = A complete meniscus ophthalmic lens with front base curve and corrected back curve

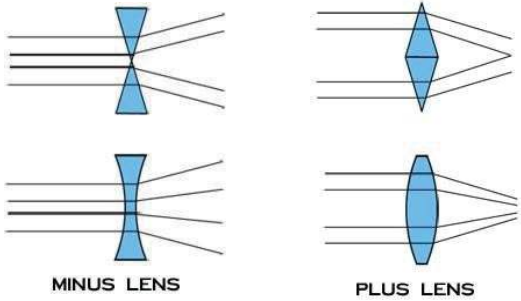

You will need to know the terms **converge** and **diverge**.

Light passing through a **plus lens converges**.

Light passing through a **minus lens diverges**.

How Light Passes Through a Lens:

Inside a prism, two very predictable things always happen to light.

THESE ARE CRITICAL CONCEPTS TO GRASP!
LEARN THEM NOW!

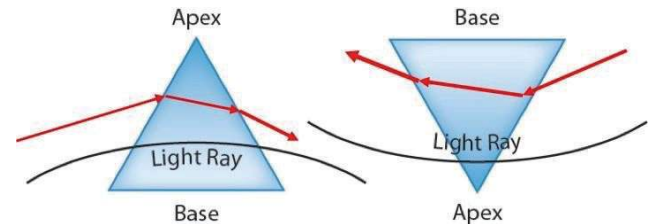

- 1) Rays of light entering a prism always bend around the base of the prism.
- 2) The image or object being viewed through a prism always shifts towards the apex.

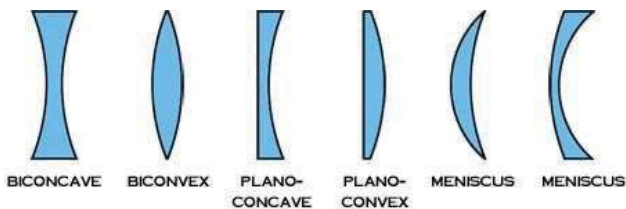

Although you may never see many of these again you will need to know these shapes for your exam.

Can you match the following?

Lenses as Prisms	Match
Minus lenses light. The shape of a modern lens is Plus lenses light. The bottom of a prism is called the. The point of a prism is called the.	A. base B. apex C. diverge D. converge E. meniscus

Do you know what makes a free-form lens so special? Want to learn tips on being a better salesperson?

Want to know the difference between a lens and lens blank? Learn more! Be more! Earn more! Be happier!

The ABO is just the beginning. Join us at: OpticianWorks.com

Lens Power and Lens Power Formulas

Note: Lens power is actually the result of the combination of lens curvature, lens material and lens thickness. These two formulas are just “short-cuts” for the exam. To really understand lens power see OpticianWorks.com.

The Nominal Lens Formula: “ $DL = D_1 + D_2$ ” is a short cut to lens powers, when DL is the total power of the lens, D1 is the front surface power, and D2 is the back surface power.

Example for spherical lens: $D_1 = + 8.00$ $D_2 = -10.00$

$$+8.00 + -10.00 = -2.00$$

So $DL = -2.00$

Example for spherocylinder lens: Prescription required: -1.00 -0.50 X 45 Front Base Curve = +2.00

Back curves to be ground -3.00 / -3.50

+8.00 Front Base Curve

-10.00 Back Curve

Rx = -2.00 Sphere

+2.00 Front Base Curve

-3.00 / -3.50 Back Curves

Rx = -1.00 -0.50 X _____

Now you try it and see how you do.

D1= + 6.00

D2= -12.00

+6.00 (+) - 12.00 = So DL =

Prescription required: -1.50 -1.00 X 45

Front Base Curve = +3.00

Back curves to be ground /

-6.00 Sphere

-4.50 / -5.50

For the ABO you will want to know base curve theory:

For a definition the base curve is, "The curve from which all other curves are measured."

In theory the goal is always the same, you want the front base curve to be as close to +6.00 as possible.

You can do this in two ways. First you can use Vogel's Rule. To find the best base curve for a plus prescription add the sphere power or the spherical equivalent to +6.00. To find the best base curve for a minus prescription add half the sphere power or half the spherical equivalent power to +6.00. To get the spherical equivalent of an Rx: Add exactly 1/2 the cylinder power to the sphere power. Use a calculator that has a simple +/- button and just add them together with the correct sign. Get your spherical equivalent FIRST then apply the rule. Treat a sphere as a spherical equivalent.

Vogel's Rule	
Plus Rx: Base Curve = spherical equivalent + 6.00 D	Minus Rx: Base Curve = ½ the spherical equivalent + 6.00

If Rx Is	Base Curve Would Be
+4.00 Sphere	+10.00
+4.00 -2.00 X 98	+9.00
-4.00 Sphere	+4.00
-4.00 -2.00 X 98	+3.50

The second way is to memorize a simple base curve chart. It may look something like this:

Simple Base Curve Chart	
When Spherical Equivalent Is	Use Base Curve
+7.50 to +12.50	+12.25
+4.50 to +8.75	+10.25
+1.50 to +5.75	+8.25
-1.75 to +1.75	+6.25
-1.50 to -5.75	+4.25
-4.50 to -9.25	+2.25
-8.50 and above	+0.25

The powers overlap so you can choose the same base curve for both eyes when the Rx is not the same in both.

Free Form Lens Design

For the ABO you will want to know theory so you can understand the basic principles behind lens design. However, today lens design is NOT simple! Free form lens design has broken away from simple curves and crude 1/8th diopter measurements. Free form lens design allows tools to work with sophisticated software to create complex, multi-dimensional, free flowing curves which are accurate to 1/100th of a diopter.

A true free form lens may have complex curves on both its front and back surfaces. These curves cannot be measured using a lens clock and cannot be accurately read in a lensmeter. Basic, two-axis, two-curve formulas are no longer valid.

Chapter 3: Lens Form

Sphere

A sphere is perfectly round and a spherical cornea or lens can be thought of like the top one-third of a tennis ball. Recall that in the refractive errors simple myopia and simple hyperopia the lenses used to correct it are spheres. A spherical lens (cornea) produces a single focal point for all the light passing through it.

Cylinder

Most prescriptions correct for astigmatism, which means that the person's cornea is misshapen. In the astigmatic eye, the cornea will be cylindrical. A cylinder has two different curves, instead of being the same in all areas. It is like the top half of a football cut lengthwise.

A lens (cornea) that is astigmatic produces a variable focus. The concept of astigmatism is very, very three-dimensional. You must picture the eye as a three-dimensional object and think about light passing through a lens, through the misshapen cornea, and the actual eye.

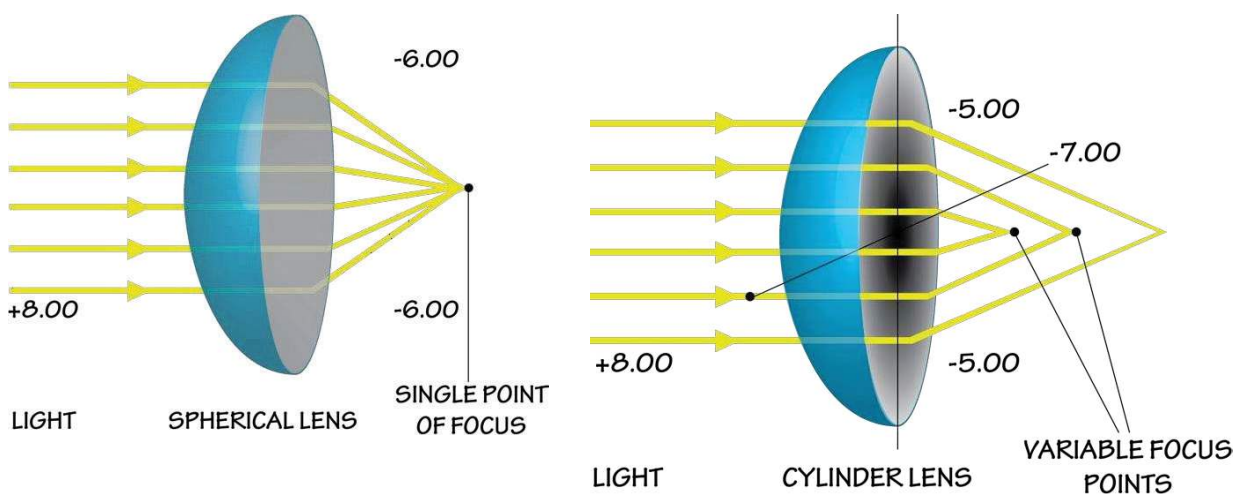

Since astigmatic corneas have different curves it means that they have different powers in different parts. This means that lenses used to correct for astigmatism must also have more than one curve and more than one power.

The Tennis Ball- Foot Ball Concept



A spherical cornea shown will have the same radius of curvature across its entire surface. All light passing through it will gather at a single point.



An astigmatic cornea will have different radius of curvature across the entire surface. Light passing through it will be focused at different points.

Axis

Since the cornea has two different curves an ophthalmic lens used to correct astigmatism has two different curves on it producing two different focal points.

These lenses are known as **toric** or **sphero-cylinder** lenses. Since the two curves can appear anywhere on the cornea we must be able to tell the lab where the high and low points are so we can place the necessary prescription, being supplied by the ophthalmic lens in the right place. Axis is a notation of position in relation to the cornea and the corrective lens.

In geometry, circles are broken into 360 degrees. Corneas and lenses are perfect circles, the axis will always be written as a number between 0 and 180, with 0 and 180 being exactly the same point.

Note: Meridians or degree lines on a lens can be shown in two ways

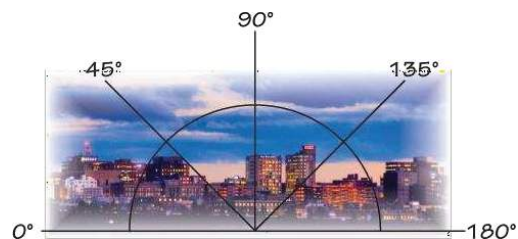
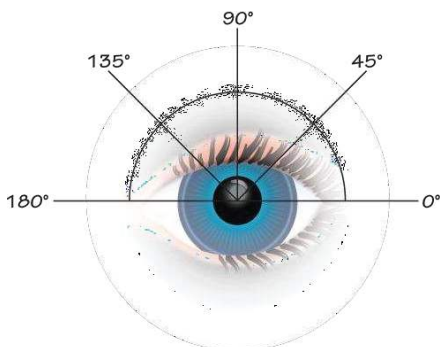

If you are facing a patient wearing a lens the notations run from 180 to 0 from left to right like this. If you are wearing the lens and looking out through it then they run 0 - 180 from left to right like this.

Aspheric Lens Design

Many lenses are designed as aspheric. This means that the front surface of the lens is tapered away from the center. This technique is used to provide a thinner lens, increase the likelihood that light hitting the lens will pass through it and to decrease optical distortion. Do not confuse the term aspheric with the terms spheric or toric.

It's time for Jeopardy Round 2!	
It is perfectly round ____ It is a notation of position ____ It has two curves ____ A misshapen cornea ____ It has a tapered base curve ____	A What is astigmatism? B What is aspheric? C What is a sphere? D What is cylinder? E What is an axis?

Flat Transposition

Flat transposition is the formula used to switch between the two different ways of writing a prescription.

Prescriptions that correct for astigmatism can be written in two different ways. The prescription power and resulting lenses are the same whether in plus or minus cylinder form.

A prescription written in minus cylinder form (-1.00 - 1.00 X 90) is the same as a prescription written in plus cylinder form (-2.00 +1.00 X 180).

Minus cylinder form is the more common way of writing prescriptions and most optical formulas will require the prescription to be in minus cylinder form before you work with them.

How to switch between the two Rx formats:

To switch between the two forms, follow this formula EXACTLY every time:

- 1) Add the cylinder power to the sphere power algebraically (using the signs)
- 2) Change the sign of cylinder "+" to "-", or "-" to "+" leaving the value the same
- 3) Move the axis by 90 degrees while staying between 0 and 180

Axis 0 - 90 add

Axis 91 - 180 subtract

Example: -1.75 - 1.25 X 67

-1.75 (+) -1.25 = -3.00 so sphere becomes -3.00

My cylinder changes from -1.25 to +1.25

My axis moves 90 degrees to 157

Rx written as -3.00 + 1.25 X 157

Now you try

Example: -2.50 -2.00 X 10

Add -2.50 and -2.00

Your cylinder changes from _____ to _____

Your axis moves 90 degrees

Rx is now written as _____

-4.50 +2.00 X 100

The Optical Cross

This is EXACTLY how a lensometer works!

Another way of looking at power(s) is by the graphical representation of power and position using the optical cross.

Another way of looking at power(s) is by the graphical representation of power and position using the optical cross.

For example, using the following Rx and using flat transposition you can place the correct power in the correct place.

$$-6.00 - 3.00 \times 45^\circ$$



$$-9.00 + 3.00 \times 135^\circ$$

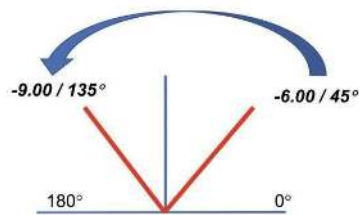

From -6.00 to -9.00 is 3.00 diopters **more minus**.

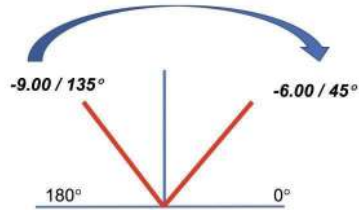

From -9.00 to -6.00 is 3.00 diopters **more plus** (less minus).

To remove an Rx from an optical cross you need to decide if you are writing it in plus or minus cylinder form.

If I start writing my Rx from -6.00 and the power 90 degrees away is -9.00 then I am taking my Rx from the cross in minus cylinder form. Since -9.00 is more minus than -6.00. So my Rx is written as -6.00 -3.00 X 45 because -9.00 is 3.00 diopters more minus than -6.00. Cylinder value is the difference in power between the two principle meridians.

If I start writing my Rx from -9.00 and the power 90 degrees away is -6.00 then I am taking my Rx from the optical cross in plus cylinder form. Since -6.00 is more plus than -9.00. So, my Rx is written as -9.00 +3.00 X 135 because -6.00 is 3.00 diopters more plus than -9.00. Cylinder value is the power between the two principal meridians.

Your Turn! Take the written Rx and put it on the optical cross.

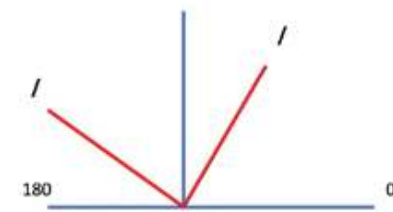
<p>-4.00 -1.00 X 60</p> <p>-5.00 +1.00 X 150</p>	
--	--

Now, take the powers off the optical cross and write them as a prescription in both + and - cylinder form.

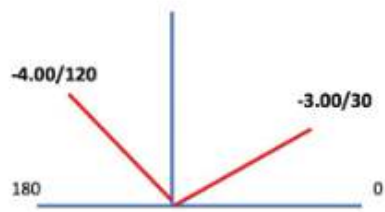
	<p>In plus form:</p> <p>In minus form:</p>
---	--

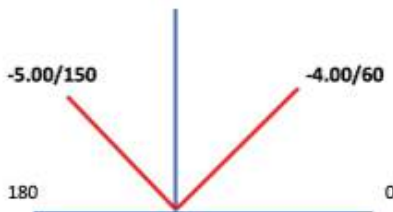
<p>-4.00 -1.00 X 60</p> <p>-5.00 +1.00 X 150</p>	
--	--

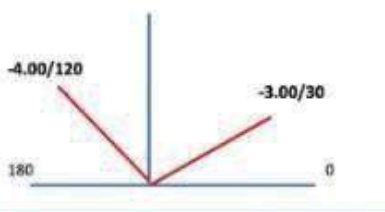
	<p>In plus form:</p> <p>-4.00 +1.00 X 120</p> <p>In minus form:</p> <p>-3.00 -1.00 X 30</p>
---	---

Prism

See Addendum for rules on prism splitting.

For some people their two eyes do not see things as being in the same place. Prism is used to alter the perceived image of an object so that the brain interprets it as being in the right place.

Dr. S Quintmore OD 235 Ramapo Valley Road Oakland, NJ 07366 201-337-4058				
DEA License # 67532 NPI # 870				
Patient: Donna Gerndt				
	Sphere	Cylinder	Axis	Prism
OD	-1.25	-0.50	90	1 BO
OS	-2.25	-1.25	95	2 BU
Add				
Notes:				
10/12/2018				
Signature of provider: <u> S Quintmore OD </u>				

The use of prism is a balance of position and power.

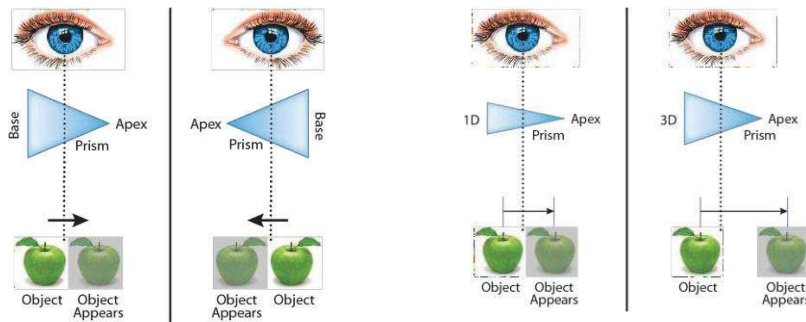

If we alter the position of the apex we will alter the perceived position of the object being viewed. If we alter the power (thickness) of the prism we will alter the perceived distance the object position will move.

Optical Center Verses Major Reference Point

In all prescriptions that do not require prism (the majority of prescriptions filled) when we fabricate or finish glasses (cut lenses to fit a particular frame), we place the lens OC directly in front of the patient's pupil, by using their "PD" or patient pupillary distance which we get with the pupilometer.

When we do this the wearer experiences NO prism.

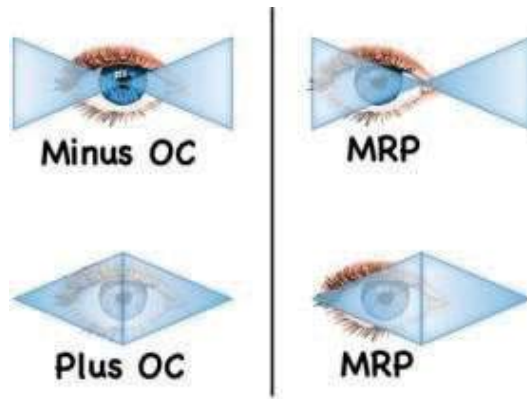

Prism occurs when we deliberately place the lens OC somewhere other than in front of their pupil. This forces the eye to look through the area of the lens that has a prismatic effect. When we place that point in front of the patient's eye that point on the lens that fills the prism required in a written prescription that point becomes the **lens major reference point or MRP**.

Working with Prism Prentice's Formula

$$P = hcm \times D$$

P stands for the amount of prism created - the answer you are looking for

hcm is the distance from where the wearer is actually looking through the lens and where they should be looking (the lens OC) in centimeters*

D stands for the lens diopter power in the meridian that you are checking

*Since we work in millimeters you must divide your result by 10

Compounding Prism - Canceling Prism

Canceling Effect	Compounding Effect
Subtract Amounts	Add Amounts
BU/BU	BU/BD
BD/BD	BI/BI
BI/BO	BO/BO

When using Prentice's formula, one must also be aware of the effects of compounding and canceling prisms. BU/BU, BD/BD, and BI/BO all have canceling effects. BU/BD, BI/BI, and BO/BO all have compounding effects.

So, in every case the final step in determining prism is the combined effect of both lenses together.

Your ABO Exam questions will be written for 90 or 180 or may require flat transposition to one or the other.

Always remember:

PD questions are done with the power at 180

- OC questions are done with the power at 90

If you are given a problem concerning patient PD and an Rx of -1.00 -1.25 X 90 you MUST do flat transposition and find the power at 180 to solve the problem.

Example:

A pair of glasses was made by the lab for a patient PD of 52mm, when the actual patient PD is 58mm (a difference of 6mm or 3mm each eye). The job order was completed correctly, but the lab made an error.

To determine the amount of prism experienced by a wearer with lenses which have been decentered 3mm too much nasally (52 is less than 58) in each eye based on a prescription of -1.00 - 1.50 x 180 OU we can use Prentice's formula.

We know that the power at 0-180 is -1.00, since the prescription tells us so. Patient PDs run along the horizontal, or 0-180, line, so we can work from there.

$$P = hcm \times D$$

P = the amount of error in layout X the power at 180

$$P = 3 \times 1$$

$$P = 0.3 \times 1$$

"0.3" is the result of converting 3 millimeters to centimeters, which the formula requires. 3 divided by 10 = 0.3

1.00 is the diopter power of the lens at the 0-180 meridian.

$$P = .3 \times 1 = .3$$

So, P = 0.3 prism diopters base out in each eye, or 0.6 base out OU (.3 + .3) since BO BO prism compounds or adds together.

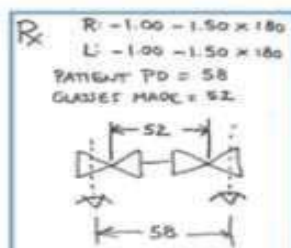

IF IN DOUBT DRAW IT OUT! Your drawing will show you exactly what the wearer is looking through. This is the only way to be 100% sure that you are providing the correct answer on any exams you may take!

With Monocular PDs:

With a monocular pupillary distance of 32/34 mm, a frame pupillary distance of 70mm, and an optician error in which no decentration occurred.

Our frame PD becomes 35/35 (70 split in half) $35-32 =$ an error of 3mm in the right
 $35-34 =$ an error of 1mm in the left

Rx is:

R: -2.00 -1.00 X180

L: -3.00 -0.50 X 180

Right eye: $35 - 32 = 3$ mm difference 3 mm to centimeters = 0.3 $0.3 \times -2.00 = 0.6$	Left eye: $35 - 34 = 1$ mm difference 1 mm to centimeters = 0.1 $0.1 \times -3.00 = 0.3$
--	---

Both errors create BI prism and BI BI compounds so you will add the two together.
 $0.3 + 0.6 = 0.9$ This patient would experience 0.9 diopters of BI prism.

*Want to learn how to use a SV lens to fill a prescription with prism saving \$\$\$\$?
Want to really understand prism? Learn more! Be more! Earn more!
Join us at: OpticianWorks.com*

Now you try one - Don't worry I have given you a little help.

A pair of glasses was made by the lab for a patient PD of 56mm, when the actual patient PD is 64mm (a difference of 8mm or 4mm each eye). The job order was completed correctly, but the lab made an error.

To determine the amount of prism experienced by a wearer with lenses which have been decentered 4mm too much nasally (56 is less than 64) in each eye based on a prescription of +5.00 - 1.75 x 180 OU we can use Prentice's formula.

We know that the power at 0-180 is +5.00, since the prescription tells us so. Patient PDs run along the horizontal, or 0-180, line, so we can work from there.

Hint: hcm = 4 and D = 5

$P = hcm \times D$

Find your hcm and divide it by 10 to convert it to mm

_____ / 10 = _____

$P = \text{_____} \times \text{_____} = \text{_____}$

So, P = _____

Now determine if the amounts cancel or compound _____

Cancelling Effect	Compounding Effect
Subtract Amounts	Add Amounts
BU/BU	BU/BD
BD/BD	BI/BI
BI/BO	BO/BO

IF IN DOUBT DRAW IT OUT! Your drawing will show you exactly what the wearer is looking through. This is the only way to be 100% sure that you are providing the correct answer on any exams you may take!

2.00 BI and 2.00 BI for a total of 4.00 D of prism

Splitting the prism refers to balancing the prescription. You usually do this when the doctor prescribes the prism in one eye only. If made as prescribed, the completed eyeglasses will appear (will be) unbalanced in both weight and thickness. Splitting the prescribed prism allows you to give the full prismatic effect by distributing the prism on both lenses. Opticians can do this if you check with the prescribing doctor to make sure that the prism is doing what the prescriber dictated. For cosmetic purposes and to equalize the weight of the lenses, the prescribed prisms should be split between the two eyes.

However, there are times when prism should not be split:

- If doing so will cause the patient to want to tilt their head in unnatural positions.
- If splitting could cause potential interference with distance focusing.
- And of course if the prescriber specifies all prism to be on the one lens indicated.

Rules for splitting prism:

- Check with the prescribing eye care professional. Most of the time this is not a problem, but there are exceptions.
- Divide the prescribed prism by 2
- Put one part into each eye
- Maintain the prescribed prism direction in the original prescription.
- Follow the rules of prism canceling and compounding.

Remember our goal is for both eyes to perceive the object being viewed as being in the right place and “fused” or appearing the same to both eyes or no “double vision.” So maybe you can even visualize how, as a concept, that might work.

For most opticians figuring out how to split prism is mostly a matter of calling the lab and asking them to do it.

For opticians destined to work for doctors that prescribes a lot prism it is very important to know the basics. As always you will gain expertise with experience.

A few years ago, I had a patient that was prescribed 2.50 BI OD and 2.50 BO OS. This actually cancels out the prism. I contacted the prescribing doctor to verify that that was what they wanted and not an error when the prescription was written. I was told that the person had been in an auto accident and had a brain injury and needed to have the prescription as written to assist with both head and gaze position.

Below are possible prism treatments for an assortment of medical conditions.

Postures and possible prism treatments:

Head Posture	Condition	Possible Cause	Prism Treatment
Left Head Turn	Right Gaze Preferred	L Lateral Rectus Paresis R Medial Rectus Paresis	Base L
Right Head Turn	Left Gaze Preferred	R Lateral Rectus Paresis L Medial Rectus Paresis	Base R
Left Head Tilt	R Hyper-deviation	Superior Oblique Paresis	BD Over R
Right Head Tilt	L Hyper-deviation	Superior Oblique Paresis	BU Over L
Head Tilt Back	Down Gaze Preferred		BU
Head Tilt Forward/Chin Down	Up Gaze Preferred		BD

Example 1

Let's take a look at three step-by-step examples.

You just received the following Rx:

OD -1.00 -0.50 x180

OS -2.00 -0.50 x180 6.00 BU

- Divide the prescribed prism by 2
- Put one part into each eye
- Maintain the prescribed prism direction in the original prescription.
- Follow the rules of prism canceling and compounding.

How would you order the above to improve appearance and wearability?

- | | |
|--|---|
| <p>A.
OD -1.00 -0.50 x180 1.00 BD
OS -2.00 -0.50 X 180 5.00 BU</p> <p>B.
OD -1.00 -0.50 x180 5.00 BU
OS -2.00 -0.50 x180 1.00 BD</p> | <p>C.
OD -1.00 -0.50 x180 3.00 BU
OS -2.00 -0.50 x180 3.00 BD</p> <p>D.
OD -1.00 -0.50 x180 3.00 BD
OS -2.00 -0.50 x180 3.00 BU</p> |
|--|---|

$$6/2 = 3$$

I need the equivalent of 6 BU OS

BD/BU compounds so I have $3 + 3 = 6$

I'm leaving my BU in my left so things should work out just fine.

The answer is D. The prescriber wants 6.00 BU for the left eye. 3.00 BD OD and 3.00 BU OS meets this requirement.

Example 2

You just received the following Rx:

OD +1.00 -0.50 x180 5.00 BI

OS +2.00 -0.50 x180

- Divide the prescribed prism by 2
- Put one part into each eye
- Maintain the prescribed prism direction in the original prescription.
- Follow the rules of prism canceling and compounding..

How would you order the above to improve appearance and wearability?

A.

OD +1.00 -0.50 x180 2.00 BI

OS +2.00 -0.50 x180 3.00 BI

B.

OD +1.00 -0.50 x180 2.50 BI

OS +2.00 -0.50 x180 2.50 BI

C.

OD +1.00 -0.50 x180 3.00 BI

OS +2.00 -0.50 x180 2.00 BO

D.

OD +1.00 -0.50 x180 2.50 BO

OS +2.00 -0.50 x180 2.50 BO

$$5/2 = 2.50$$

To get a compounding effect I need BI/BI

$2.50 + 2.50 =$ that equivalent of 5 I need

So 2.50 R 2.50 L both BI gets me what I need.

The only answer that meets the prescriber's requirement is B. You need to have the horizontal prism to be the same direction to compound the prism.

Example 3

You just received the following Rx:

OD -1.00 -0.50 x180 4.00 BD 3.00 BO

OS -2.00 -0.50 x180

You are thinking that prism splitting might work here.

- Divide the prescribed prism by 2
- Put one part into each eye
- Maintain the prescribed prism direction in the original prescription.
- Follow the rules of prism canceling and compounding.

Let's run with it.

How would you order the above to improve appearance and wearability?

A.

OD -1.00 -0.50 x180 2.00 BD 1.50 BI

OS -2.00 -0.50 x180 2.00 BU 1.50 BI

B.

OD -1.00 -0.50 x180 3.00 BU 1.50 BI

OS -2.00 -0.50 x180 1.00 BD 1.50 BI

C.

OD -1.00 -0.50 x180 2.00 BU 1.50 BO

OS -2.00 -0.50 x180 3.00 BD 1.50 BO

D.

OD -1.00 -0.50 x180 1.00 BD 1.50 BO

OS -2.00 -0.50 x180 2.00 BU 1.50 BO

The only answer that meets the prescriber's requirement is D. You need to have the horizontal prism to be the same direction to compound the prism, and the required vertical prism.

Chapter 4: Lens Options

Here are two terms to know related to lenses:

1. **Abbe value:** Another term related to lenses is “Abbe value.” The Abbe value is a numerical description of how prone a lens is to breaking light down into its component colors. The higher the Abbe value of a lens, the less likely it is to bend the light too far and create a chromatic aberration.
A “good” Abbe value is in the high forties and low fifties, and a “bad” Abbe value is in the thirties. You are sure to have a question about Abbe value on the ABO.
2. **Specific Gravity:** The higher the specific gravity of a material the more material is packed into a smaller area. Substances with a specific gravity greater than one are denser than water and those with a specific gravity of less than one are less dense than water, and will float.

Lens Materials

Material = Glass

Also called: crown glass Ordered from lab as: “glass” $n = 1.53$

Abbe = 58

Suggested Prescription Range: All spheres, all cylinders

Good for: Scratch resistance, optics, holding coatings, chemical resistance Bad for: Weight, safety, availability, processing time

Material = Plastic

Also called: CR-39, PSR for plastic-scratch-resistant coated, basic plastic Ordered from lab as: “plastic”

$n = 1.49, 1.50$

Abbe = 58

Suggested Prescription Range: All spheres, all cylinders

Good for: Cost, optics, holding coatings, basic prescriptions, tinting Bad for: Thickness, weight, will crack or break if drilled

Material = Polycarbonate

Also called: many different trade names like Thin & Light, Featherweights, Polythin, etc... Ordered from lab as: “poly”

$n = 1.586$

Abbe = 31

Suggested Prescription Range: +/- 2.00 through +/- 6.00 Spheres, low cylinder (less than 1.50) Good for: Availability, safety, weight, high spherical prescriptions, all children, people with one eye Bad for: Optics, holding a coating, prescriptions with higher cylinder, will not tint (unless it has tintable coating applied), low Abbe value

Material = Mid-index (note mid-index lenses are no longer available but appear to still be on the ABO)

Any material with an index over 1.53 and under 1.585 Ordered from lab as: lab will tell you what you are getting n= will vary

Abbe = Will vary with material

Suggested Prescription Range: All spheres, all cylinders +/- 2.00 through +/- 6.00 cylinders over 1.50

Good for: Mid to high range prescriptions, can be tinted, can be used in place of poly for reduced thickness, good optics, holds coatings well

Bad for: Limited availability

Material = Trivex

Also called: Many different trade names like Phoenix, NXT, ImpactX,

Ordered from lab as: "Trivex"

Abbe = 43-45 depending on manufacturing process n= 1.53

Suggested Prescription Range: All spheres, all cylinders (see notes)

Good for: Mid to high range prescriptions, can be tinted, can be used in place of poly for weight and safety, good - great optics, holds coating well

Bad for: Thickness which is often equal to plastic (CR-39)

Material = 1.6X High index plastics 1.6X (1.60, 1.66, 1.67)

Ordered from lab as: specific index as in "1.67" Abbe = 36 - 42 depending on manufacturer

Suggested Prescription Range: All spheres, all cylinders, very high prescriptions +/- 4.00 through +/- 15.00

Good for: High prescriptions, holding coatings, optics

Bad for: Cost, inconsistent tinting, some labs will not drill certain 1.6X lenses Notes: Should have an AR coat for best optical performance

Material = 1.7X High index plastics 1.7X (1.70, 1.74)

Currently the highest index "plastic" available Ordered from lab as: Specific index as in "1.74" Abbe = For 1.70 is 36 and for 1.74 it is 33

Suggested Prescription Range: Very high prescriptions +/- 5.00 through +/- 15.00 Good for: Edge thickness in higher prescriptions

Bad for: Cost, optics becoming compromised with aberration Notes: Must have an AR coat to reduce distortion.

Contrary to what you will see and hear. No lens material can be assumed to be safe or impact resistant.

Time for Jeopardy Round 3 (Isn't this fun!)

It has an "n" of over 1.53 and under 1.586 _____
It can also be called "crown _____"
It is the highest plastic index _____
It is thin, light and has good optics
It is also called CR-39 _____

- A What is Trivex?
- B What is 1.74?
- C What is glass?
- D What is mid-index?
- E What is plastic?

Lens Material & Thickness

This may be a good time to put this to heart. Make it a chant, song or saying that you memorize.
It will never let you down!
The shorter the radius - the steeper the curve - the steeper the curve - the higher the power. The higher the power - the thicker the lens - in a given material.

It is an absolute rule in opticianry that the smaller the eyewear or eyewire opening, the lighter and thinner the glasses will be. As lens size increases, lens thickness proportionally increases therefore the larger the lens, the greater the thickness. The greater the thickness, the more material you have. The more material you have, the heavier the lens will be.

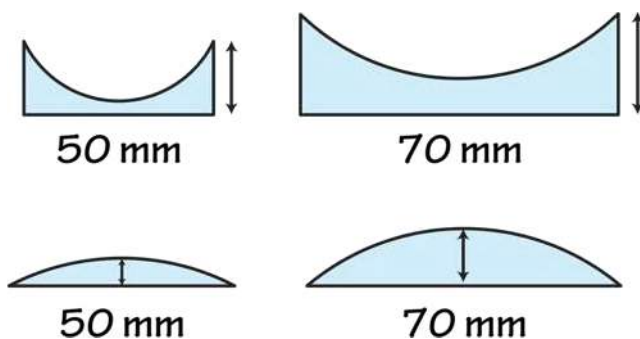

Follow the golden rule of opticianry: In minus lenses, the larger the eyewire opening, the thicker the edge will be and in plus lenses, the larger the eyewire opening, the thicker the center will be.

You always want to put your patient in the smallest possible frame that fits correctly.

AR or Non-Glare Coatings

A/R treatments are scientifically engineered to provide an amazing array of benefits for any lens.

- They allow better light transmission
- They provide a scratch protection layer
- They may include a hydrophobic layer that resists fogging and prevents water from beading up on the lens when it rains
- They may have an oleo-phobic layer that resists smearing from facial or skin oils
- They may include an anti-static layer to reduce attraction of dust



A MULTI-LAYER AR COATING

- OIL REPELLENT
- DIRT REPELLENT
- WATER REPELLENT
- ANTI-STATIC
- ANTI-REFLECTIVE
- SCRATCH RESISTANCE

The optical advantages provided by A/R treatments include better vision in all lighting situations, but particularly in low lighting situations. The primary optical advantage of A/R treated lenses is enhanced vision when driving at night. In addition to the better sight provided by greater light transmission, A/R treated lenses also provide cosmetic benefits. Individuals who are looking at the wearer see directly into their eyes, instead of seeing reflection or glare from the surrounding lighting.

Photochromics: (Changeable Tint Lenses)

These lenses darken when exposed to the sun and return to clear when brought indoors. Adding a quality AR coat to a photochromic lens increases their sensitivity and decreases reaction time. Photochromic technology is available in all lens materials and almost all lens styles

Polarization

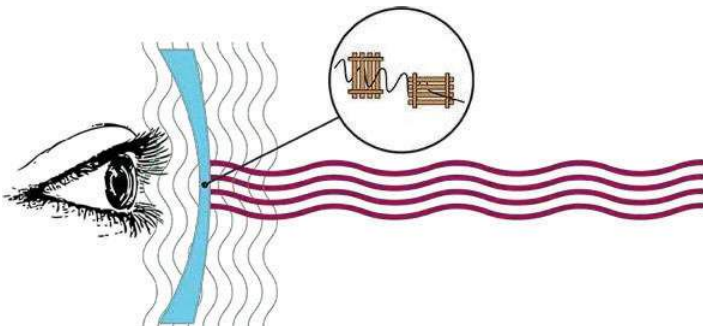

You are sure to have that question on the ABO.

Tinting

A polarized lens is actually a sandwich lens with a front piece, a polarizing filter, and a back piece.

Polarizing filters block a HORIZONTAL wave of light that we see as glare off of surfaces while allowing vertical waves to pass through.

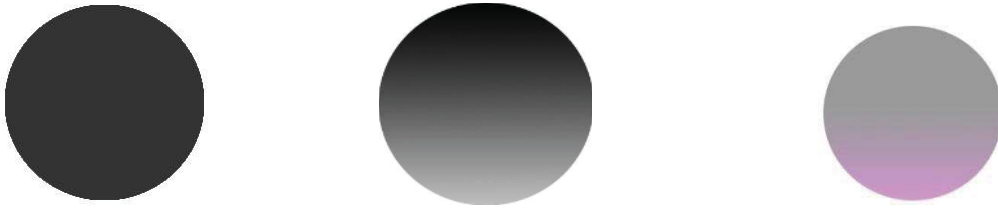

Solid Tints:

As the name suggests the tint is a consistent color and depth over the entire lens. The depth or density of color will range from barely visible to a shade lighter than a sunglass.

Gradient Tints: Gradients provide variable color throughout the lens, generally starting with a darker or greater depth of color near the top of lens, which gradually becomes lighter near the bottom.

Double Gradients: A double gradient lens contains two colors, generally starting with a darker or greater depth of color near the top of the lens, which melds into a second, lighter color near the bottom of the lens.

Sunglasses:

UV protection is considered good when less than 5% of UV rays pass through the lens (95% of UV rays are being blocked). It is best to have 2% transmission or 98% blockage.

Tints are ordered from the lab using either a 1-2-3 scale or a percent scale.

Tint Depth by Expression		
By Number	By Percent	By Description
0.5	55%	Very light – barely visible
1	60%	Very light – but visible – cosmetic
1.5	65%	Light
2.0	70%	Visible, cosmetic
2.5	75%	Light sunglass
3.0	80%	Normal sunglass
3.5	85%	Dark sunglass
Polarized		“A” Very light
Polarized		“B” Light
Polarized		“C” Normal for polarized

WORDSEARCH PUZZLE – Find the following words	
Lens Add-Ons	
<p> O O D L G W M X U A C Y C V G P O L A R I Z E D I W Y I O G P N P F P Z P N B P C O M T F T K O A G O F O T N I T O T K F F E N L X H O T Y Q R R A N W B W I G P G N V T J O H G C W V S L O L R Q Y O Q K C Y U I H G R O O A H R S F I O R Q Y T D Z M P D R S N Q V T D E Y Y I R R O I N E X R Q O I Y H N P F D Q E J P D S J H H C S W O H L S N Y U I D S P N E Z N M M Z C T H W O I Z V O R A R M T M Q W A Q L W A S Y G Q Z C J R U E U R J F T Z J S </p>	<p>NONGLARE</p> <p>TINT</p> <p>GRADIENT</p> <p>POLARIZED</p> <p>PHOTOCHROMIC</p> <p>HYDROPHOBIC</p>

Multifocals

Lined bi-focals are used to correct all the refractive errors plus the error or condition of presbyopia.

These lenses will have two (bi) distinct areas of clear vision.

Some common terms and numbers associated with lined style bi-focals:

ST 25, 28, 35, 45 ST stands for Straight Top, and the number indicates the width across the add segment. They will also be called Flat Tops or be marked FT. ST 28s are the current industry standard for bi-focals.

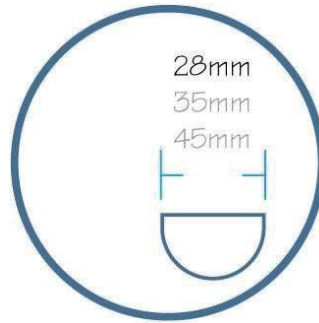
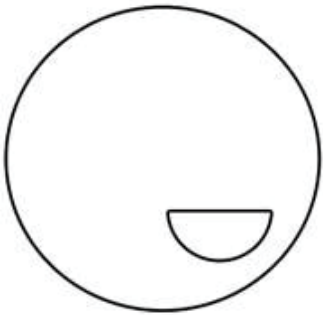

Lined tri-focals are used to correct all refractive errors plus the error or condition of presbyopia.

These lenses will have three (tri) distinct areas of clear vision.

Some common terms and numbers associated with lined style tri-focals:

ST 7 X 28, ST 8 X 35 ST stands for Straight Top, the first number 7 or 8 indicates the height of the intermediate zone and the second number 28 or 35 indicates the width of the segment.

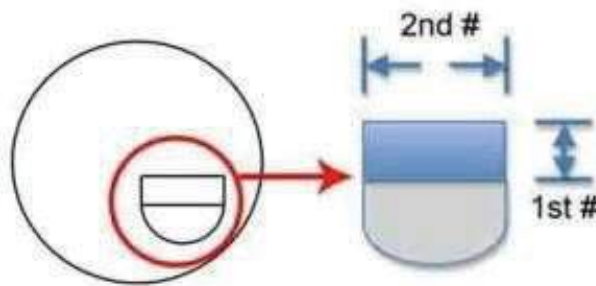
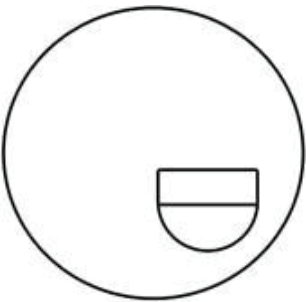

Executives are literally two different lenses split in half and then glued or fused together.

A round segment bifocal lens looks like this.

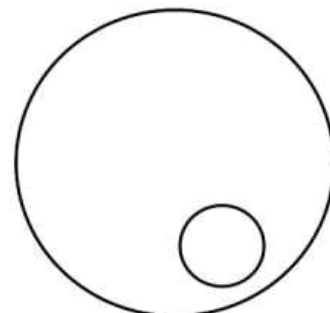
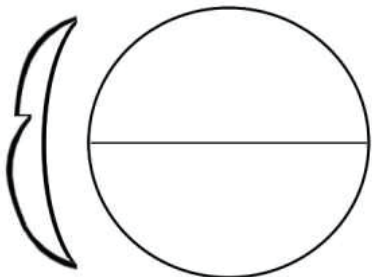

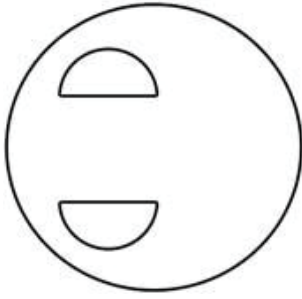

An occupational lens looks like this. They are designed for people who have to see things up close but are above their line of sight.

Another addition to the 11/2023 edition of The Ultimate ABO Study Guide.

Freeform lens design is primarily used for the creation of progressive lenses. Freeform means exactly that - the back surface of the lens is fluid in its shape. It is not based on the traditional simple one or two curves of the past.

This allows for a lens that is easier to adapt to and provides wider areas of usable lens. In addition to the advanced surfacing techniques freeform design may take in account point of wear measurements or POWs.

The only way to squeeze enough on these concepts into the study guide is to provide you with a link out to two YouTube videos. If you cannot access the videos you will need to find another resource.

Compensated Lens Design: <https://youtu.be/je0cq8zV54Y?si=RPN2bMDZ6rKF6Ty3>

Lens Tilt: <https://youtu.be/tNEWWRk4jaNs?si=LhZ86AsfR8QYhRUa>

To answer any questions concerning compensated lens design you'll need to use the process of elimination and watch for the tell-tale clues.

Compensated lens design will use vertex distance, frame wrap and frame tilt in the calculations.

Know the rules for how vertex distance changes the perceived power of a lens and you will be 90% of the way there.

Then look for where your power will change because of wrap or tilt.

When the lens is tilted along the 90th meridian panto-retro-neutral cylinder is changed along 0-180

When the lens is wrapped along 0-180 then the change occurs at 90.

Then watch for the answer that compensates the lens to the perceived lens powers NOT the original power and you'll get the answer right.

Progressives

Progressive lenses (also known as PALs for progressive addition lenses) are used to correct all refractive errors plus the condition of presbyopia. Unlike lined bifocals a progressive lens has a smooth continuous building of power from distance to near through an intermediate "corridor".

Example: If my Rx was +2.00 Sphere with a +1.50 Add power the lens would look something like this.

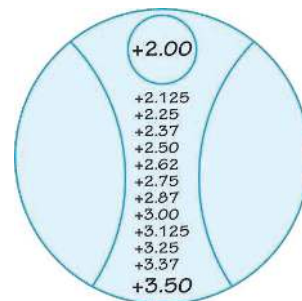

Since one of the goals of a progressive lens is meeting the vanity needs of the wearer, the add power zones of a progressive are invisible to the naked eye.

So you know how to position the lens prior to cutting it to fit a specific frame, the temporary markings shown below (Progressive Markings) are actually painted on the lens.

The permanent (laser or etched) markings shown (Invisible Laser Markings) are actually part of the lens.

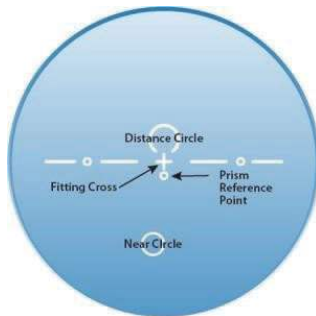

Painted On Markings

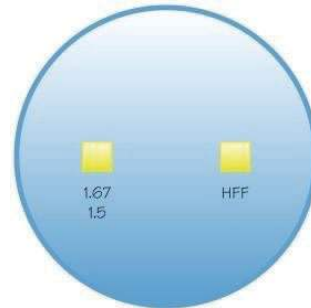

Invisible Laser Markings

Associated with progressive lenses:

Fitting height: Tells the optician how much room is required in the frame eyewire opening so the wearer will be able to use all the necessary areas the lens has to offer.

Corridor length: The corridor is the area of the progressive lens that contains the intermediate viewing powers. It is measured from just below the distance circle to just above the reading circle.

The corridor will build in power towards from the distance prescription to the full reading prescription. The shorter the corridor length the faster the power will build and the more sensitive to head and eye movement the lens will be for the wearer.

*Do you know there is a special progressive lens designed just for the office? Want to learn how to block a progressive for finishing?
Learn more! Be more! Earn more! Be happier!
Join us at: OpticianWorks.com*

Slab Off

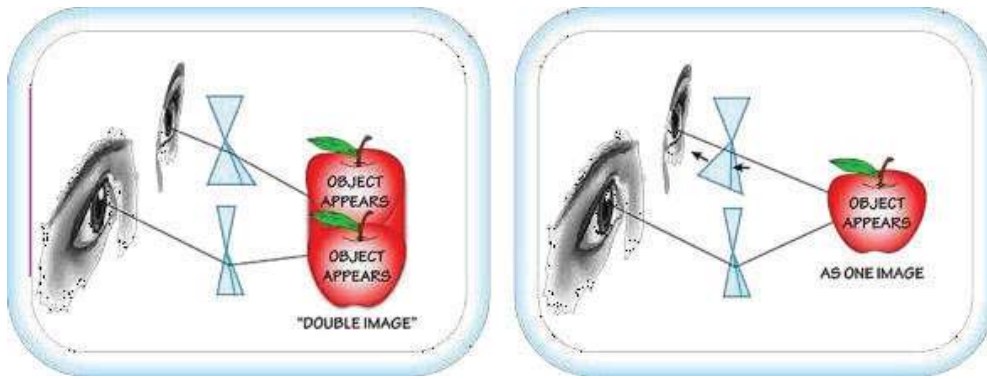

Slab-off, or **bicentric grinding**, is a method of correcting vertical imbalance for patients with **anisometropia**. Anisometropia is a condition in which the eyes have unequal refractive power. Anisometropia may be caused by differing amounts of either myopia or hyperopia between the eyes. In some cases, one eye will be myopic while the other eye is hyperopic, a condition known as **antimetropia**.

When this condition exists, unequal refractive powers result in differing amounts of induced prism as the eyes move away from the optical center of the lenses, often causing **diplopia or double vision**. This may be corrected by adding Base Up prism (slab-off) or Base Down prism (reverse slab-off) to one or both spectacle lenses.

Generally, vertical imbalance does not become troublesome for the patient until it reaches 1.5 diopters of imbalance. Some patients are able to tolerate much more imbalance while others much less.

Conventional Slab Offs are always ground base up in the most minus or least plus powered lens in the 90° meridian.

You are almost certain to see this question on the ABO.

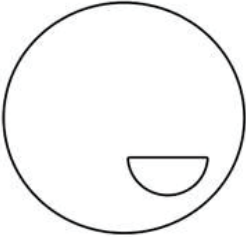
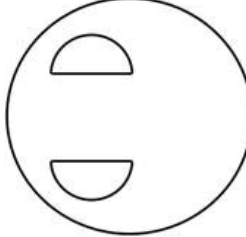
Can you match the image with the name?		
 <p>A</p>	 <p>B</p>	<p>A</p> <p>B</p>

Chapter 5: The Written Prescription

Dr. Mark Roth OD 235 Ramapo Valley Road Oakland, NJ 07366 201-337-4058				
DEA License # 67532				
NPI # 870				
Patient: Heidi Klum				
	Sphere	Cylinder	Axis	Prism
OD	-1.25	-0.50	90	
OS	-2.25	-1.25	95	
Add				
Notes:				
10/12/2018				
Signature of provider: <u> Mark Roth OD </u>				

Sphere: If the prescription form contains numbers only in the sphere area, then the prescription has been written to correct the simple refractive errors of either myopia or hyperopia.

Cylinder: A prescription will only contain a cylinder value when the prescription has been written to correct astigmatism. If a prescription has a cylinder power, then it must also have an axis.

Axis: Is a notation of lens position.

Dr. S Quintmore OD 235 Ramapo Valley Road Oakland, NJ 07366 201-337-4058				
DEA License # 67532				
NPI # 870				
Patient: Donna Gerndt				
	Sphere	Cylinder	Axis	Prism
OD	-1.25	-0.50	90	
OS	-2.25	-1.25	95	
Add	+ 1.25			
Notes:				
10/12/2018				
Signature of provider: <u> S Quintmore OD </u>				

Add: A prescription will only contain an add power when the prescription has been written for a presbyopic patient. The add power tells us how much magnifying power we need to provide the patient so they can see things up close again.

Notes found on prescriptions:

Balance: Balance means that the patient is blind in one eye. This immediately tells you that you will use either polycarbonate or Trivex to protect the eye with sight.

You will match the power of the other lens if it a sphere and use the “spherical equivalent” if the prescription is a sphero-cylinder.

To obtain a spherical equivalent:

Use a calculator with a -/+ Key!

Sphere power + $\frac{1}{2}$ the cylinder power added together.

Prescription: -1.50 -1.00 X 56 = -2.00 Spherical equivalent

Since $\frac{1}{2}$ of -1.00 is -0.50 and $-1.50 + -0.50 = -2.00$

Prescription: -4.50 - 2.00 X 78 = -5.50 Spherical equivalent

Since $\frac{1}{2}$ of -2.00 is -1.00 and $-4.50 + -1.00 = -5.50$

Now You Try It

Prescription: -5.00 - 3.00 X 95 provide the spherical equivalent:

Since $\frac{1}{2}$ of _____ is _____ and _____ + _____ =

-6.50

Vertex Distance:

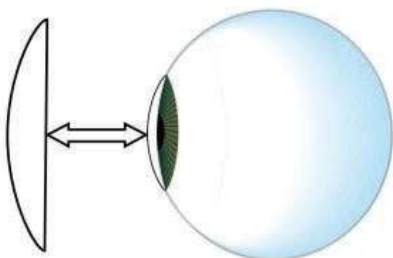

Vertex Distance

Vertex distance is the distance from the front of the cornea to the backside of an ophthalmic lens.

Lenses will be perceived as having more or less strength depending on the distance they are set from the eye.

THE RULES ARE:	
A Plus Lens	
Moved Towards The Eye	Loses Perceived Power
Moved Away From The Eye	Gains Perceived Power
A Minus Lens	
Moved Towards The Eye	Gains Perceived Power
Moved Away From The Eye	Loses Perceived Power

The most important thing to remember when understanding the concept of vertex distance is that in ALL circumstances, more vertex distance equates to more perceived plus power.

Learn The Rules! You will have at least one question on the ABO that has to do with the change in vertex.

This is a good time to review a tricky concept:

“Less minus is more plus; less plus is more minus.”

-7.00 is “more plus” than -9.00. They are both minus powers, but -7.00 is “more plus” than -9.00.

+7.00 is more minus than +9.00 is. They are both plus powers, but +8.00 is “more minus” than +9.00.

NVO: Means “Near Vision Only.” This prescription is for single vision glasses made only for close up work.

DVO: Means “Distance Vision Only,” and means that an add power has been provided on the prescription, but it should be ignored and not made in a multi-focal or progressive.

Intermediate or Computer: These are single vision glasses made for intermediate distances.

Conversion of a prescription with an add power provided to single vision readers.

Should your patient want a pair of single vision glasses for near work or intermediate work only and presents a prescription with separate distance prescription and an add power, you can combine them and make a pair of single vision “readers.”

You do this by following this simple formula EXACTLY:

For near: Sphere power added to add power algebraically. Everything else remains exactly the same. Take the new power and use it for the sphere power in your prescription.

For intermediate: Sphere power added to HALF the add power algebraically. Everything else remains exactly the same. Take the new power and use it for the sphere power in your prescription.

In the case of the hyperopic person, this is pretty straightforward. If the distance prescription is +1.75 and their add power is +2.00, they will be looking through +3.75.

However, in your myopic patients, this is a little difficult to understand. Let us say the patient's prescription is -3.50 and the doctor prescribes an add power of + 2.00, when looking through these glasses, he or she will be looking through -1.50.

The thing to remember is that less minus power is more plus power!

Examples:

<p>Prescription = - 3.00 -0.50 X 123 Add +1.50 Single vision readers would be -1.50 -0.50 X 123 Since -3.00 (+) + 1.50 = -1.50</p>	<p>Prescription = - 3.00 -0.50 X 123 Add +1.50 Single vision intermediates would be -2.25 - 0.50 X 123 Since ½ of +1.50 is +0.75 Since -3.00 (+) +0.75 = -2.25</p>
<p>Prescription = +2.00 - 1.25 X 89 Add +1.50 Single vision readers would be + 3.50 - 1.25 X 89 Since +2.00 (+) +1.50 = +3.50 For intermediate powers, take half the add power and follow the same steps.</p>	<p>Prescription = +2.00 - 1.25 X 89 Add +1.50 Single vision intermediates would be +2.75 - 1.25 X 89 Since ½ of +1.50 is +0.75 Since +2.00 (+) +0.75 is +2.75</p>

Now You Do It	
<p>Prescription = - 4.00 -1.50 X 115 Add +2.00 Single vision readers would be = Since ____ (+) + ____ =</p>	
<p>-2.00 -1.50 X 115 -4.00 (+) +2.00 = -2.00</p>	

Chapter 6: Frames

How Frames Are Measured

Should your patient want a pair of single vision glasses for near work or intermediate work only and presents a prescription with separate distance prescription and an add power, you can combine them and make a pair of single vision "readers."

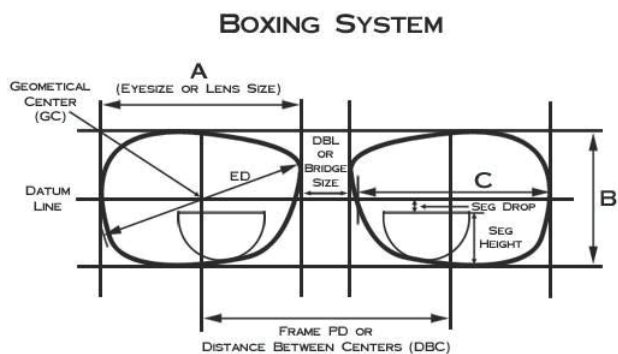

The proper tool for measuring frames is a good old fashioned PD stick. The one thing we do not use a PD stick for is taking a PD.

There are four basic components to frame sizing: The **A**, the **B**, the **DBL**, and the **temple length**.

In the United States, eyeglass frames are measured using the boxing system.

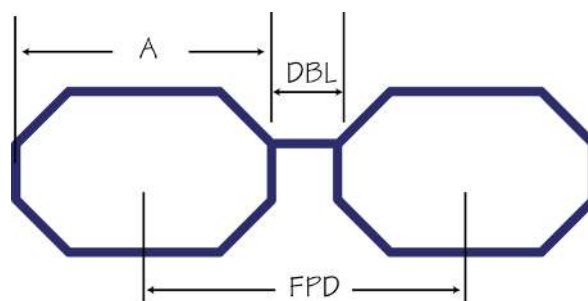
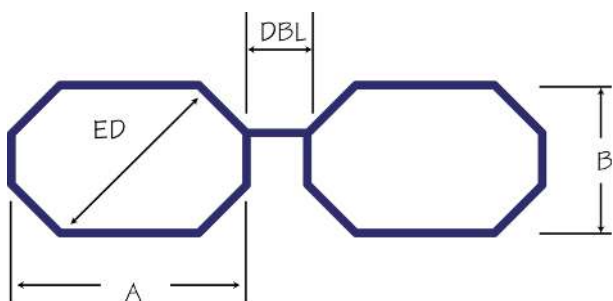

$$A + DBL = \text{Frame PD}$$

$$\text{Frame PD} = \text{FPD} = \text{Geometric Center of Eyewire Openings}$$

The frame A is the longest horizontal opening in the eyewire.

The frame DBL is the closest measurement between the two lenses.

The frame A and DBL work together to provide frame size. Example: The Gorbot Extra comes in size 56 – 19.

The frame A and frame DBL added together provide the Frame PD (pupillary distance): $A + DBL = \text{Frame PD}$. The frame PD is used in laboratory finishing to calculate lens decentration (the displacement of the lens OC to match the patient PD).

Example: A frame with an A of 58 and a DBL of 16 has a frame PD of 74. This also represents the **geometric opening of the frame eyewires**.

The third component of frame size is the “B”. When a prescription calls for a progressive lens, you will also have to provide a “B” measurement to the lab for lens fabrication.

- The “B” measurement is the longest vertical measurement in the eyewire opening.

Example: A frame with an A of 58 and a DBL of 16 has a frame PD of 74. This also represents the **geometric opening of the frame eyewires**.

The fourth component in frame size is the **temple length**. The standard temple length for an adult frame is 140 mm. Temples will run from 130 – 145 mm on standard adult frames and from 120 – 140 on children’s frames. In general, temple length will increase as the A and DBL increase.

Can you fill in this drawing of the boxing system?	
Frame Measurements	Match
	<p>A B DBL ED</p>

The Parts of an Eyeglass Frame

Chassis (also known as frame front): When connected by a solid bridge of any kind (metal or plastic), the chassis is the combination of eyewires, bridge and the end pieces. This includes any crossbars above the bridge, and any artful details applied to any of those pieces (like rhinestones).





Temples (also known as temple arms or arms): Temples are the pieces that hold the chassis to the head and ears. The temple is the piece that runs from the end piece on the chassis back to behind the ear. The temple also holds half the hinge assembly.

Temples come in three types:

1. The **“skull”** temple being the most prevalent found on 95% of all glasses. It has a temple end that bends around the back of the ear, ends approximately mid-ear, and then bends in slightly towards the head, hugging the skull.
2. The **cable** temple, found on shooting glasses, glasses for infants, and some safety glasses. It has temple ends that are sprung and that wrap around the entire ear, holding the glasses firmly in place.
3. Once called a **“library”** temple. This temple goes straight back, hugging the skull above the ear, never curving down at all. Now, many modern designs have returned to this style of temple for fashion and are called **“sport”** temples. Many modern sport sunglasses also use a straight back design without any special designation.

Bridge: The bridge is the area between the two eyewires.

- On a plastic frame, it is the area that touches the nose and the area that connects the two eyewires together.
- On a metal frame, it is only the area that connects the two eyewires together.
- On a three-piece mount it is the entire assembly that connects the two eyewires together in the middle.



Nose pads: Nose pads are the small pads designed to contact the nose and hold the frame up off the nose and away from the face.

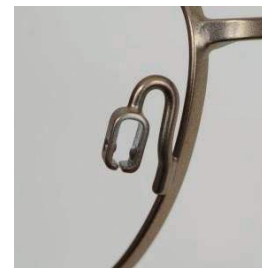

Guard arms: Guard arms are the small wire arms that actually hold the nose pad in place.

Eyewire: The eyewire is the area of the frame that actually surrounds the lens and holds the lens in place.



Chassis End Piece: The end piece is the area of the chassis that meets the temple or the point where the temple attaches to the chassis. It is where the other half of the hinge is found.

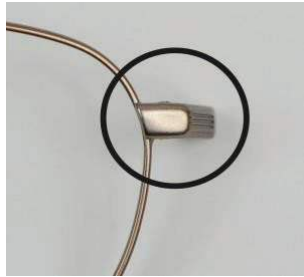

Hinge: The hinge is the point where the temple is connected to the chassis. It allows the temple to fold in and out.



Name the part:



Frame Materials

There are two kinds of frame materials: metals and plastics.

Metals have four general types:

1. **Monel (or basic, nickel-based, metal frames):** These are inexpensive and make up the bulk of all low and mid-range metal frames made today.

Advantages of Monel-based frames:

- Easy to adjust
- Hold adjustments well
- Very strong
- Relatively light in weight
- Can have a wide range of colors and plating like bright gold and bright silver
- Economical
- Can be repaired by solder

Disadvantages of Monel -based frames:

- Outermost plating (the layer that touches the skin) can wear off, which can cause skin allergies or reaction to nickel in Monel metal
- Prone to breaking after repeated bending
- Once plating is worn away, metal may erode quickly and create abrasive areas and sharp edges
- Monel is the heaviest of metal frame materials in use

2. **Stainless steel:** Is used in many mid-range to high-end frames.

Advantages of stainless steel frames:

- Can be light in weight because of reduced material
- Corrosion resistant
- Very strong
- Very little chance of allergic reaction to metal, but, NOT hypo-allergenic
- Holds adjustments very well

Disadvantages of stainless steel frames:

- Limited range of colors
- Colors tend to be matte in finish
- Temples rarely made in any shape other than “paper clip”
- Larger frames can become heavy

3. **Titanium:** Is used in many mid-range and many high-end frames. A titanium frame of equal size may weigh half as much as an identical frame in Monel.

Advantages of titanium frames:

- Titanium is hypo-allergenic: it will not cause reactions with skin
- It is extremely lightweight
- It is 100% corrosion proof
- Very strong.

Disadvantages of titanium frames:

- Titanium is not easy to manufacturer, and not all companies provide the same quality of production
- Frames can be legally labeled 100% titanium yet contain other metals

4. **Flexible or memory metals:** are metals with flexible properties, and are usually a mix of titanium and other metals. A mix is called "**beta-titanium**".

Advantages of flex metal frames:

- Bend instead of break
- Return to original shape after being bent
- Have spring-like quality that helps hold glasses in place on head
- Lightweight

Disadvantages of flexible metal frames:

- If not well designed with adjustment points built in, frames may be impossible to adjust
- You may find fitting difficult on people with unusual or very asymmetrical face shapes

The second frame category is **Plastics** and plastics really have one general category, and then an odd collection of other materials.

4. **Zyl or Zylonite:** makes up the bulk of all plastic frames on the market today. If a frame is plastic, chances are excellent that is Zyl. Zyl is also called **acetate** or **cellulose acetate**. Although not 100% accurate, plastic and zyl are used interchangeably.

Advantages of Zyl frames:

- Light in weight
- Huge range of colors
- Strong
- Fairly easy to adjust
- Can be molded in any shape and size

Disadvantages of flexible metal frames:

- Can lose shape and even be ruined by high heat (dashboard of car in direct sun)
- Will discolor over time
- Will dry out and become brittle over time
- Will stretch out and lose fit in hot weather

Other “plastic” materials in use:

Polyamide (Nylon): These frames are sold under brand specific names. Polyamide frames are lightweight, can be translucent, have high UV resistance, and are chemical resistant. Polyamide frames usually have the note “Cold Insert” on the demo lens.

Optyl: Stronger and lighter than frames made of zyl frames made of Optyl are available. The advantages of Optyl frames are offset by the tricky nature of the material. Optyl is actually a memory plastic which can be heated, formed, and when cooled will maintain the shape until heated again.

Are you ready for Jeopardy Round 4?

We also call it plastic ____

Flexible titanium frames are made of this ____

It is strong and resists corrosion ____

It is a nickel based frame material ____

It is another name for Zyl ____

A What is cellulose acetate?

B What is beta-titanium?

C What is stainless steel?

D What is Zyl?

E What is Monel?

Do you know that there is a third way to take a PD?

Want to know the trick to taking a fitting height through a dark sunglass lens? Learn more!

Earn more!

Know more than your customer does! Visit us at: OpticianWorks.com

Verifying frame and lens parameters and other physical characteristics.

Primary Frame Fitting Considerations

One: The first thing to consider when fitting a frame to a patient’s head is the width of the frame. This means how the temples fit the sides of the patient’s head.



A properly fitting frame will have its temples leave the frame front, or chassis, and go straight back, touching the person’s head just before their ear. There is simply NO EXCEPTION to this rule.

Two: Next we need to look at the nose. If the frame is plastic and has a solid bridge (almost all do), then the frame either fits, or it does not. There is simply NO EXCEPTION to this rule. Look at the patient's nose, and see how the frame fits it.

- If the frame contours the nose well and has great contact across the entire bridge, then it fits.
- If you can see gaps or light showing between the nose and the bridge then it does not fit, and the patient must choose another frame.
- If the frame rests on only two points the patient must choose another frame.

On metal frames you need to check that the bridge is the correct width for the patient's nose. Metal frames come in different bridge widths. Depending on your patient you may need to find a frame with a 16 or 18 bridge and one with a 21 for another. You cannot use the nosepads to correct for a poor bridge fit.

Three: Check that the **temples** are long enough to curve over the ear properly and hold the glasses in place. Check that they are not so long that they will be annoying to the wearer.

Develop the habit of performing these checks now, and remember the rule of three:

Can you fill in this drawing of the boxing system?	
<p>The Fitting Triangle One -- Width Two -- Nose Three -- Temple length</p>	
<p>When the frame is put on the patient's face, it touches at three points: The junction of each ear and the skull and the bridge of the patient's nose.</p>	

If the frame is to be used with a progressive lens, then the frame "B" must have enough depth to include the progressive lens's full range of powers.

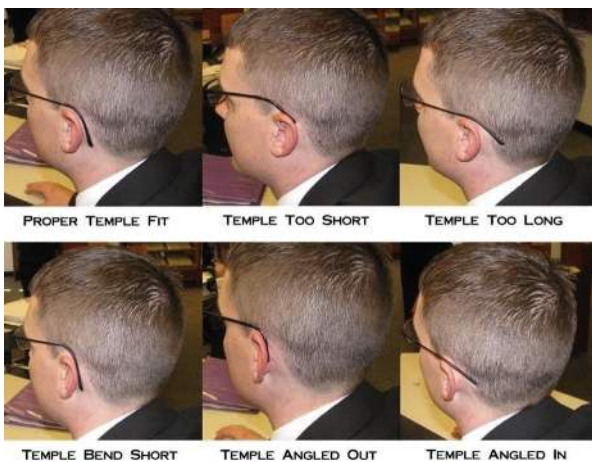

Temple bends: Should begin immediately after it passes over the top of the ear. It should be rounded and smooth, and should hug the ear to just past mid-point then angle away.

The very end of the temple should turn in slightly to hug the skull. The bump just behind the ear is the **mastoid** and the bend that touches that spot is the **"mastoid bend"**.

Three terms to know for the ABO:

1. Frontal angle – The angle of the pads when viewed from the front of the frame. The tops of the pads should be slightly closer together than the bottoms of the pad following the contours of the nose as it gets wider from top to bottom.
2. Splay angle – The angle of the pads when viewed from the top of the frame. The front edges of the pads should be closer together than the back edges.
3. Vertical angle – The angle of the pads when viewed from the side of the frame. Since most frames will have some amount of pantoscopic tilt, the bottoms of the pads should be slightly closer to the frame front than the tops.

You will also use nose-pads to lower or raise the frame.

- If you spread the nose-pads out, the frame will come down the nose.
- If you move them closer together, you will force the frame up.

This will allow you to alter the cosmetic look of the frame in relationship to the wearer's eyebrows. Adjusting the nose-pads is also an important adjustment when fine-tuning the fit for a progressive lens.

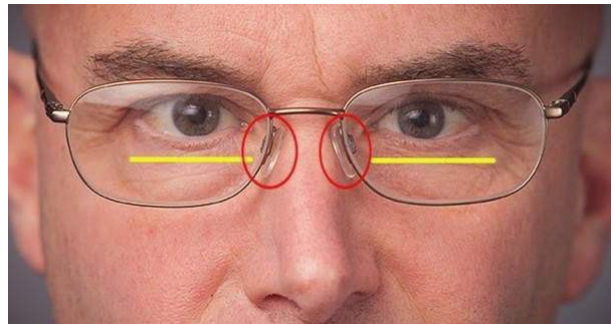
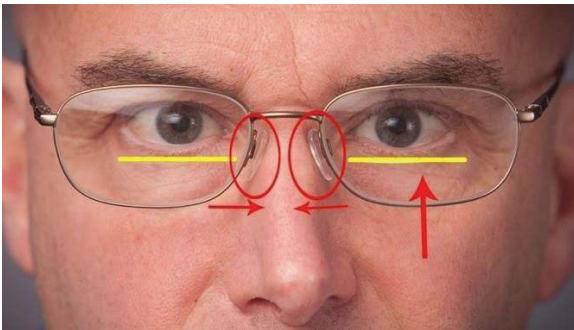

This is how you use nosepads to correct for small changes in multifocal and progressive heights.

You level a frame by angling the temple up or down from where it meets the chassis. Using your fingers or the wide jaw pliers “twist” the temple in the direction opposite of what you need the frame to do. If I angle the temple down (create more force where the temple meets the top of the ear) the frame will go up.

This may require a bend of several millimeters.

Which temple you choose to move in what direction is a matter of practice and experience.



If I push the right temple down, the right side of the frame front will move up.

If I push the left temple down, the left side of the frame front will move up.

If I pull the right temple up, the right side of the frame front will move down.

If I pull the left temple up, the left side of the frame front will move down.

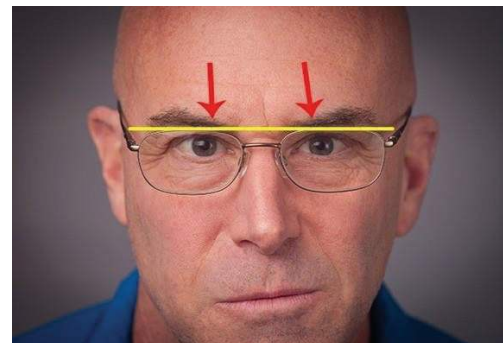
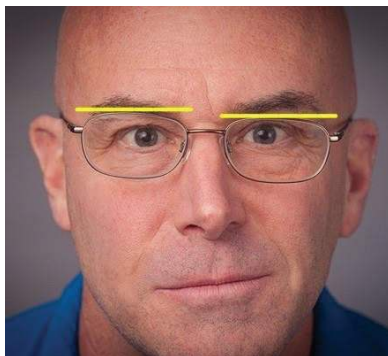
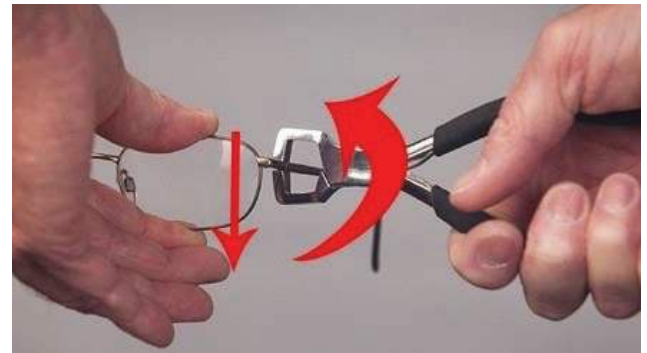

In this image using the eyebrows as a guide (or bifocal segments) the frame sits quite level providing a cosmetically appealing appearance.

How to add vertex distance:

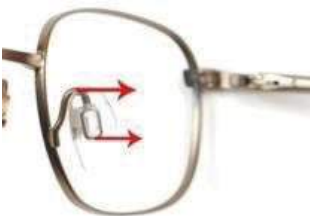

“My eyelashes are hitting the back of the lens.” To pull a frame away from the wearer’s eye, first reduce the temple bend very slightly and see if it helps. If changing the temple bend slightly does not help, and the frame has nose-pads, then pull the nose-pads back from the eyewires towards the wearer’s face. This will push the frame front out away from their eye.

Name that drawing:

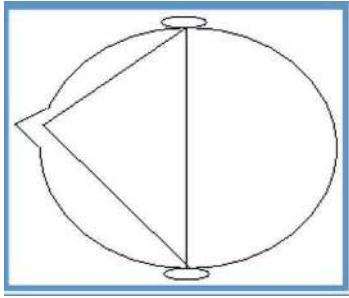

- A 1, 2, 3
- B The rule of three
- C The fitting trifecta
- D The fitting triangle
- E The fitting tree

Adjusting Frames:

Metal frames are adjusted as they are. There is no need to heat a metal frame for adjustment. To adjust a plastic frame, two types of heating elements can be used, the "salt pan," which now contains heated glass beads, and the more modern hot air blower. When using heat to perform adjustments, it is best to hold the frame in the heat source in the position you desire (stressed) until you feel it begin to bend. The moment you feel it begin to move, remove it from the heat source and hold it in place until it cools, or run it under cold water to cool the frame.

Standard Alignment

You WILL have questions on the ABO about these angles, terms, frame alignments and adjustments.

Standard alignment, also called standard adjustment(s), or bench alignment: These are the adjustments that a frame SHOULD have before it ever leaves the lab and reaches a patient. It is a "standard" alignment because it places the frame in a neutral position that provides you, the optician, with a good place to start when adjusting the frame for an individual wearer.

1	Tighten ALL Screws
2	Check for any X-Ing
3	Check Co-Planar
4	Check Skewed Bridge
5	Check Face-Form

6	Check Pantoscopic Tilt
7	Check Temple Parallelism
8	Check Open Temple Angle
9	Check Temple Fold Angle
10	Check Adjustable Pads

Tighten all screws: If you fail to tighten all the screws prior to trying to align the frame, you will be “bending against nothing.”

Check lens co-planar alignment: When the lenses are parallel, but one lens is farther forward than the other, the lenses are misaligned. This misalignment will be seen when viewing the frame from above. Coplanar misalignment occurs from the bridge being pushed forward or backwards while the lenses remain “on axis” and in correct tilt. This misalignment is corrected by using your fingers and thumbs to gently bend the bridge back in place.



Check for X-Ing: Which refers to the lenses being twisted about the bridge. The bend occurs at the point where the eyewires are attached to the bridge. Think of one lens having pantoscopic tilt and the other having retroscopic tilt (see below). This misalignment will be seen when viewing the glasses from the side. It is corrected by grabbing the eyewires and gently bending them in place as if you were wringing out a washcloth.

Check for skewed bridge, or skewed eyewires: A skewed bridge occurs when a lens is rotated inward or outward around the bridge. This misalignment will be seen when looking at the glasses straight on from the front. A useful tool for checking this alignment is the prescription alignment gauge.

To correct a skewed bridge or lens, grab the eyewire(s) and simply rotate them in or out from where they meet the bridge until the eyewires are level across the frame while assuring that the bridge is straight across.

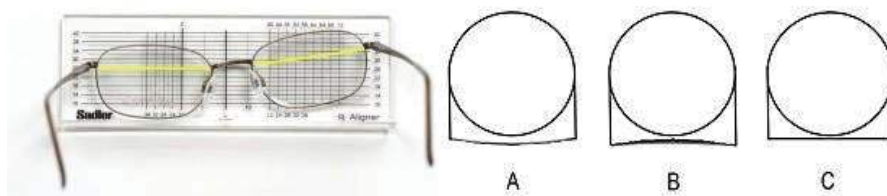

Check face-form: Face-form is the curvature of the frame front to the patient’s face as seen from above.

There are three distinct types of face-form.

1. Positive
2. Negative
3. Neutral

The desired alignment is shown in **Figure A: Positive Face-Form**, in which the frame front sits slightly curved to match the curvature of the wearer's face. The bridge of the frame sits slightly more forward than the end pieces. Some amount of positive face-form is required, both for good cosmetics and for good optics.

The alignment that needs to be corrected is shown in **Figure B: Negative Face-Form**, in which there is a slight outward curvature of the frame front from the wearer's face or from the bridge. The end pieces of the frame are more forward than the bridge when viewed from above. This is both cosmetically unacceptable and optically incorrect.

Some frames will have no face form or have a **Neutral Face-Form as shown in Figure C**, which is a frame front that is perfectly flat. The end pieces and the bridge look straight upon the same plane. This is often acceptable. However, a better cosmetic result may still be achieved with some positive face-form.

Note: Excessive face-form in any direction will create change in the perceived lens powers, and can create serious problems for some wearers.

Check Pantoscopic Tilt: Frame tilt occurs at the temples where they are attached to the chassis and form an angle, or tilt slightly downward, forcing the bottom of the eyewire slightly in towards the cheek when viewed from the side.

The desired position for the temple and frame front is **Pantoscopic Tilt as shown in Figure A**. Pantoscopic tilt is present when the bottoms of the eyewires are closer to the face than the tops of the eyewires. Some pantoscopic tilt is needed for good cosmetics and for good optics.

To create or reduce pantoscopic tilt, you need to use temple-angling pliers, your hands or a similar tool. While firmly holding the eyewire, bend the temple up or down.

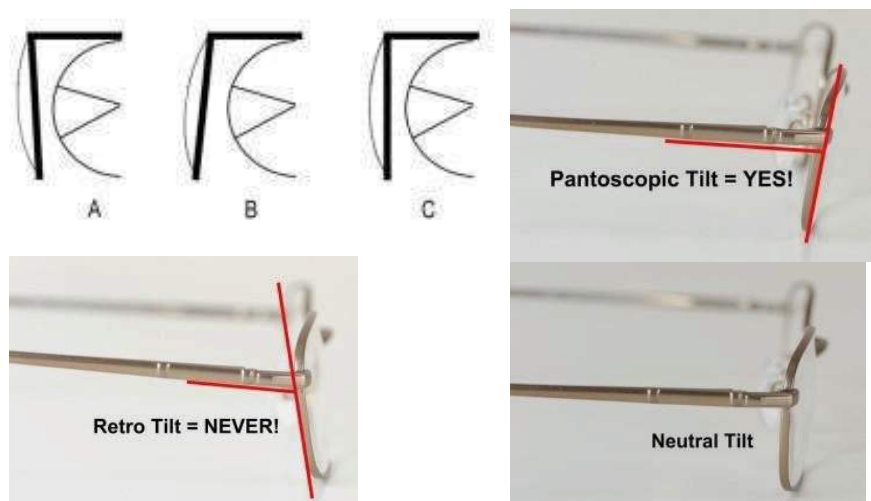

The misalignment that must be corrected in standard alignment is **Retroscopic Tilt as shown in Figure B**. Retroscopic tilt is present when the bottoms of the eyewires sit out further from the face than the tops of the eyewires. This is cosmetically unacceptable and can create a variety of optical distortions for the wearer.

Check temple parallelism: See if both temples are parallel to each other. Your test for parallelism is the **“flat surface touch test”**. Turn the frame UPSIDE DOWN on a flat surface. If the frame front (or the tops of both eyewires) and both temples make contact with the flat surface, the temples are parallel, and the frame is in correct standard alignment. To correct temple parallelism, simply use the same tools and methods that you do for tilt and adjust only one temple.

Note: This test is made with the frame “on its back” not with the temple tips!



Check for open temple angle: Which occurs when the open temples create a 90° angle with the chassis. The temples may be angled out slightly by a degree or two. However, they should never be angled in, since this will actually push the glasses away from the wearer’s face. To correct this misalignment, use the soft-hard pliers, and carefully bend the temple where it meets the chassis while holding the eyewire firmly.

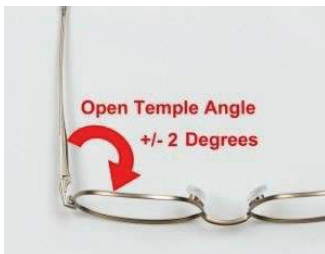

Check the temple fold angle: Which refers to the position of the temples when they are folded over, closed, and about to be placed into their case. When the temples are closed, the temple **tips should not touch the ocular surface of the lens**. The tips should rest on the edges of the eyewire. They should cross over each other at the middle of the bridge area, coming as close to parallel as possible. To correct temple fold angle, with the temples folded or closed, use your hands, the hard-soft pliers, or the wide-jaw temple angle pliers designed for that purpose.



Check adjustable pads: On metal frames, we must also look at the nose-pads. Just think about how a human nose is shaped! Place the pads in the position that best represents the human nose.



A properly aligned frame will give the patient an immediate positive experience. A properly bench-aligned frame will feel good to the patient and set the stage for a positive dispensing experience.

Dispensing a frame that is not in good bench-alignment is like starting off with, "One hand tied behind your back..." Which, makes dispensing pretty hard to do.

Match the concept or terms with the adjustment

Pantoscopic - retroscopic ____

Positive, neutral, negative ____

90 degrees to + 2 degrees ____

Eyewire rotated around bridge ____

Should never touch ocular surface of lens ____

A Face Form

B Open Temple Angle

C Temple Fold Angle

D Tilt Angle

E Skewed Bridge

Measuring

The most important thing to keep in mind when taking heights is body position. You must be on the same level as your patient looking directly in to their eye.

NO LOOKING DOWN AT PATIENT



NO LOOKING UP AT PATIENT



YES LOOKING STRAIGHT AT PATIENT

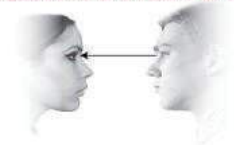

This is good technique for marking a patient's OC, segment height, fit height, or a difficult PD. Note that I am using my left hand to steady my right and that the patient is relaxed, level headed and looking straight ahead.



Patient Pupillary Distances

The measurement most often taken is the **patient's pupillary distance, or patient PD**. The patient PD is used to place the lens's optical center (OC), or lens's major reference point (MRP), directly in front of the patient's pupil, or visual axis.

A **corneal reflex pupilometer, or CRP**, is used to measure the PD. The CRP is a sophisticated tool that accurately and repeatedly measures patient PDs.

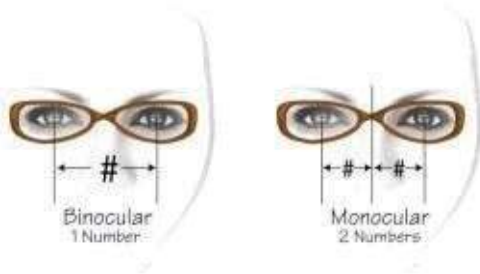

1)

Monocularly: A separate measurement is taken from the center of the patient's nose to the visual axis in the right eye and left eye. Monocular PDs should be taken for every single job except those that will be used for lined-style multifocal lenses.

Record monocular PDs on a patient record or lab order form as two numbers, such as 32/31, 29/28, 28/28, or 33/34. These numbers will be read to a lab as "PD 32 over 31" or simply as "PD 32- 31." It is assumed that the first number provided will be for the right eye.

2)

Binocularly: A binocular PD is a single measurement taken from the visual axis of the right eye to the visual axis of the left eye. It is used only for lined multifocal lens. Because we can actually see the lined segment, failing to use a single balanced number would create a cosmetic or visual imbalance in the appearance of the glasses.

Record binocular PDs on a patient record or lab order form as a single number, such as 64, 58, 56, or 66. This number will be read to a lab as "PD 64."

How to use a CRP

The CRP has two gliding levers that control wires directly in front of the patient's eyes. To read a patient's PD, the optician slides the levers so the wire blocks the sparkle of light being reflected back.



The CRP has three windows that display the monocular and binocular distances. Monocular PDs are read from the right and left windows, and the binocular PD is read from the single window.

*Do you know when it is OK to fit a little high?
Do you know when it is OK to fit a little low?
Want to learn how to choose the best lens for your customer?
Learn more! Be More! Make More!
Join us at: OpticianWorks.com*

Electronic Measuring Devices or EMDs like the OptikamPad are now the preferred method of capturing most measurements.

OC Heights

OC heights are taken to tell the lab where to place the lens OC vertically in the eyewire opening. Many opticians will start taking lens OC heights whenever the Rx is over 4.00 diopters. There is no rule or standard for when to take them.

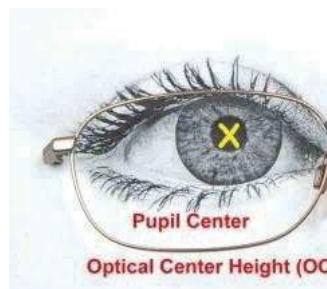

- Place yourself across from and at the same height as the patient.
- Adjust the frame so it sits correctly on their nose and is in the position in which they like to wear the frame.
- Dot the demo lens directly in front of their pupil.
- Determine half the B measurement for the frame.
- Measure the distance from half the B to the dot.
- Note the OC height clearly on lab order ticket

Bifocal Heights

- Place yourself across from the patient and at the exact same height as the patient.
 - Ask the patient to put on his or her old pair of glasses, if available, and note the position of the segment. Most people wearing lined multifocals have been wearing them for years and will know exactly what you are asking.
1. Does it appear high, low, or is it a textbook fit?
 2. If it appears high, be sure to ask if the patient must lower his or her head in order to see over it.
 3. If it appears low, ask them if they feel they have to tilt their head back to read.
 4. Ask specifically if they have had problems in the past with the segment being too high or too low.

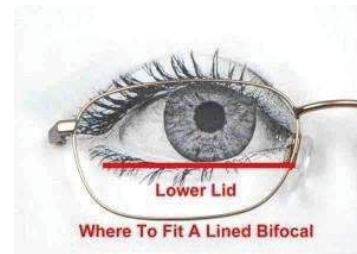
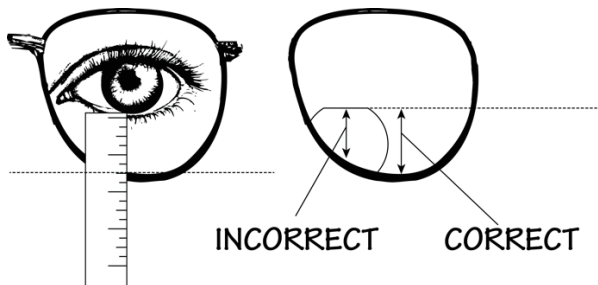

- Adjust the new frame so that it sits correctly on the patient's nose and is positioned where he or she likes it. Explain the importance of this. Say, "I need you to position the frame exactly where you like to wear it so I can mark where the bifocal will be." Adjust the frame so it sits correctly on their nose and is in the position in which they like to wear the frame.
- With the patient's head in a relaxed position and looking straight at you draw a line on the demo-lens that matches the highest point of their lower eyelid, which is where the top of the bifocal will be.
- Your goal is to provide the lab with the exact number of millimeters from the lowest point of the eyewire to the top of the segment.
- Remove the glasses and measure from the lowest point in the eyewire to the top of the line and record the measurement on your lab order form as the segment height, or "seg" height.

Don't forget to take the binocular PD measurement.

Trifocal heights: Same as bifocal with mark being made at lower pupil margin.

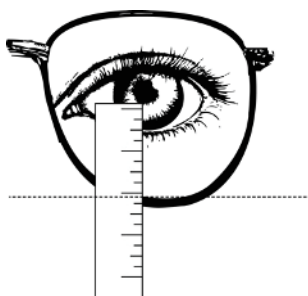

Occupational heights:

Use the same fitting techniques you use for lined-bifocals. The placement of the upper segment in an occupational lens is determined by the placement of the lower segment.

Progressive heights:

Use the same fitting techniques you use for lined-bifocals but mark the pupil center.

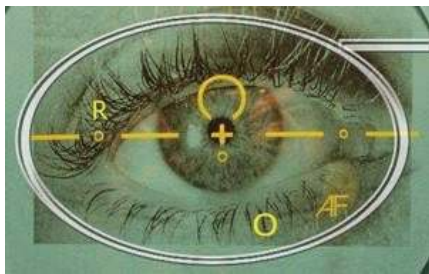

Image to the left is an actual progressive lens showing exactly how it is meant to be positioned.

THIS IS WHAT YOU ARE AFTER!

(L) The pupil center is the correct textbook place to fit a progressive. (R) The second method if you are consistently having remakes for heights too high is to use the bottom of the pupil.

Can you match the image to the proper measurement?		
Measurements		Match
<p>A</p>	<p>B</p>	<p>A:</p> <p>B:</p>

Applying Product Knowledge

Lifestyle selling techniques are about the time you spend “getting to know your patient” and asking them specific, open-ended, questions about their life. An open ended question is a question that is not easily answered with **“yes” or “no” but requires a complete response.**

- Do you play golf? Yes – No

Instead

- Tell me all about what you struggle with when you are playing golf?

You are listening for anything that suggests a certain type of frame, lens, add-on, multiple pairs of eyewear, etc.

- “I’m really hard on glasses” = titanium frame
- “I live to fish” = polarized lenses
- “I spend all day at a computer” = single-vision intermediate pair
- “I drive for a living” = two pairs one sunglasses and one clear with non-glare

Let’s look at some examples:

Mrs. Nickerbottoms is 45 years old and mentions that she is starting to have trouble reading small print.

You say, “Tell me about what you do for work?”

She says, “I’m an elementary school teacher.”

You recommend: progressives, non-glare and photochromic lenses.

Progressives will allow her to see all the ranges she needs (books, whiteboard and even across the playground), non-glare will help her see better and reduce glare off computer screens while photochromics will work when she goes outside for recess.

Mr. Jones has just retired and tells you he is devoting his life to fishing.

You say, “What kind of fishing do you like to do?”

He says, “I love to fly fish. Anytime I can you will find me waist deep in a stream catching trout.”

You recommend a ST 35 in a polarized sunglass.

The ST style bifocal will give what he needs to work with the very small flies and knots. The segment style will give him great distance viewing with no distortions. While the polarized lenses will allow him to see into the water and spot fish.

Tommy is a wild and crazy kid (-4.00 OU) about to head off to summer camp.

You ask his Mom, "Does Tommy has a spare pair of glasses and is either pair a sunglass or photochromic?"

She says, "No, he just has the one pair of clear."

You recommend that Tommy gets a second pair of glasses in a "kids" frame with polycarbonate lenses and photochromic.

Since Tommy needs his glasses he should have a second pair with him while he is away, you suggest a tough-flexible "kids frame" so they survive his time at camp, you put him in poly to protect his eyes and give him lightweight while photochromics will be perfect for his indoor-outdoor time at camp.

Mrs. Reynolds loves to paint watercolors. She tells you that she is headed off to school in the valley.

You say, "What type of painting do you do?"

She says, "I do landscapes and I even mix my own colors while I paint. I love playing with the palette and I even change colors through the day.

You recommend a high-end free-form progressive with non-glare coating.

You suggest a high-end progressive since you know she is particular about what she sees, you suggest a progressive since she is working with every range from distance to extreme near and you suggest a non-glare coating to keep colors their most natural.

Get the idea?

Match the following

Do you work? ____

Do you play sports? ____

Tell me about what you do for work ____

Tell me about your favorite sport to play ____

A Closed ended question

B Open ended question

Applying Product Knowledge

Dispensing a pair of glasses means delivering them to a patient.

It involves:

- Checking for fit
- Making adjustments for their unique face
- Checking their vision with the new pair
- Education on the lenses, care, and any add-ons they purchased

Always check behind their ears for temple bends; look at nose-pads if applicable; and look at how the frame sits on their face.

Make adjustments as necessary, and then ask the patient to put the glasses back on.

Ask:

1. "How do they feel?"
2. "Do they feel OK behind the ears?" Checking their vision with the new pair
3. "Look down and shake your head around a little, are they sliding at all?"

To check the temple length, you must LOOK behind the patient's ears to see if the bend is correct. You DO NOT have eyes on the ends of your fingers so do not think you can tell by "feeling" around back there!

Have the patient turn their head, lift their hair, and LOOK!

To check the fit of any adjustable nose pads you must LOOK at the patient's nose. Really LOOK!

To check if the frame is sitting level you will need to STARE at the patient and look at the distance from the top of the eyewire to their eyebrows.

Present the patient with a micro-fiber cloth for cleaning routine smudges. Explain that they should use the cloth when they know that what is on the lens is a fingerprint or facial oil. Explain how to clean glasses by using a lens cleaner spray or mild dish soap. Dry the lenses with a quality paper towel or a soft cotton cloth like a T-Shirt. Remind them not to use glass cleaners or any ammonia based products of any kind, and not to dry-wipe the lenses.

Dispensing Multi-Focals and Progressives:

First time lined multi-focal wearers require a little more information than a single vision wearer. It is necessary to point out that due to magnification in the lower portion of the lens things down by their feet will not be where they appear when looking down through the lower part of the lenses. They must be very careful when approaching stairs and curbs, and be sure to drop their head and look through the top.

First-time progressive wearers require a slightly different approach, and need to be educated on how to use the progressive lenses. Explain that, unlike other glasses they may have had, progressive lenses require a short adaptation time.

- First, have patients relax their shoulders, look into the distance, and look STRAIGHT ahead. Ask, "Is your distance vision good?"
If the answer is "Yes," then hand the patient a reading card. Reading cards are samples of printed material with graduated-sized fonts.
- Point to an area of print just larger than newspaper print, and tell the patient, "Keep your eyes on the print, but move your chin up and down. You should see the print come in and out of focus. Do you see how that works?"
If they say "Yes," point to an area of print on the reading card that is this size of print on a computer screen
- Ask the patient to tilt their head back just slightly and see where that line of print comes into focus.

Trouble shooting

Most often your best tool in trouble shooting a problem pair is the patient's old pair of glasses. If problems arise you will want to copy the old pair as much as possible. Bend the new pair to fit like the old pair. Mimic every bend you can. Copy face form, tilts, and try to get the lens OC position as close to the position of the old pair as possible.

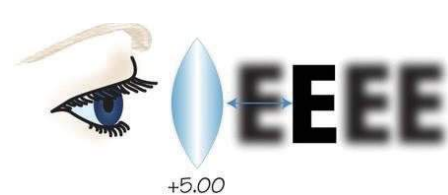
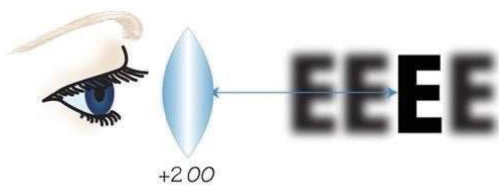

If you take nothing else away from this guide remember this concept! The stronger a plus lens is the shorter the focal length.

That means the closer you will need to hold an object to see it clearly.

This includes the add portion of a lined multifocal or progressive. You will find examples of this concept almost every day of your life when working as an optician.

When a patient complains about their vision through a new pair first find the written prescription from the doctor, NOT the lab order form, and then double check the prescription in the lensometer against the written Rx.

Then go on and check the patient pupillary distance and all heights. This will assure that the prescription is correct, as written by the doctor and that the patient measurements (PD and heights) are correct.

In trouble shooting progressives or complaints about “seeing the line” in a multi-focal ask the patient if dropping their head or raising their head clears up the problem.

- If they need to drop their head to see clearly in the distance, then the lens is fit too high. If the answer is “Yes,” then hand the patient a reading card. Reading cards are samples of printed material with graduated-sized fonts.
- If the frame has nose pads spread them apart and this will drop the frame and lens down.
- If the frame is plastic, you may try adding a little pantoscopic tilt which will give the wearer the perception that the lens has been lowered.

Assuming the glasses were made correctly double check fit paying close attention to face form and pantoscopic tilt angle. It is the opinion of many doctors and opticians that most patient complaints stem from poor fittings. Add a little positive face form and add a little pantoscopic tilt and ask the patient to try the glasses again. Be sure to get progressive lenses as close to the patient’s eye as possible.

Patients reaction to unwanted prism

If the patient is **experiencing base down prism** they may say they feel like they are standing in a bowl, walking uphill, or that objects appear stretched out vertically.

In **base up prism** they may feel like they standing on a hill or that the world seems convex, that vertical objects appear shorter, or that they feel like they are walking downhill.

In **base in or base out prism** patient may describe objects as being tilted of that they appear higher or lower than they are.

True or False Lighting Round – You have 10 seconds – GO!

You have eyes on the end of your fingers. **T F**

Education on lenses, care and add-ons is done during the initial sale. **T F**

It is OK to use glass cleaner on new lenses. **T F**

The Rx was verified so no need to ask about vision through the new pair. **T F**

The higher the plus power the shorter the focal length. **T F**

Chapter 7: Tools

The Lensmeter

The Marco LM-101 is the most widely used manual lensmeter in the industry today.



1. Eyepiece	7. Magnifier
2. Reticle Adjustment Knob	8. Axis Adjustment Knob
3. Prism Compensator	9. Filter Control
4. Lens Marker	10. Inclination Control
5. Gimbal (Lens Holder)	11. Power Drum
6. Eyeglass Table	12. Eyeglass Table Control

Part Descriptions

1. **Eyepiece** – The eyepiece must be adjusted to zero out the lensometer for their Rx. This is done by turning the eyepiece counterclockwise to the most plus setting and then slowly turning the eyepiece clockwise towards the minus until the reticle comes into focus.
2. **Reticle Adjustment Knob** – AKA Chrome Knurled Sleeve
3. **Prism Compensator** – Lensometers have an attached rotary prism that allows the operator to dial in 0 to 25 diopters of prism anywhere from 0 to 360 degrees. Some older model lensometers do not contain a prism compensator, but do have a ledge that allows the use of auxiliary prisms usually in increments of 3, 6, and 9 prism diopters to help neutralize high amounts of prism.
4. **Lens Marker** – The lens marker is a simple device consisting of three spring loaded pins that dip into a water soluble ink to mark the lens horizontally with the center pin marking the direct point being read through the lensometer. Note that the lens marker pins and ink pad can be replaced and the ink pad requires occasional re-inking.
5. **Gimbal (Lens Holder)** – The lens holder is the arm that swivels into place to hold the lens or frame stable while taking a reading. The circular piece on the end that swivels and has legs that touch the lens is referred to as a gimbal.
6. **Eyeglass Table** – The eyeglass table is used to keep a frame mounted and lens aligned properly for measuring the correct axis of the lens. The table often bisects a scale mounted on the lensometer body used to measure height of the optical center.
7. **Magnifier** – Some lensometers have this optional component which allows the operator an easier view of the axis wheel by magnifying the scale.
8. **Axis Adjustment Wheel** – The axis adjustment wheel allows the operator to align the primary and secondary power meridians in the lensometer. This is done by spinning the mires inside of the lensometer body.
9. **Filter Control** – The filter control is a small knob used to apply a green filter to the lensometer lamp for a more comfortable view through clear material while allowing this same filter to be removed for a brighter view of filtered lenses.
10. **Inclination Control** – The inclination control is used to loosen the lensometer body from the base, this allows the operator to adjust the viewing angle of the lensometer for easier viewing.
11. **Power Drum** – This wheel is usually incremented in steps of 0.12 diopters, with higher powers being incremented in steps of 0.25 diopters.
12. **Eyeglass Table Control** – The eyeglass table control is used to move the eyeglass table to align the frame mounted optics.

The first step to using a lensometer is to focus it for individual use. Failing to focus the instrument for your own eye can cause reading errors of half a diopter or more.

How to focus a lensometer for individual use.

- Position the instrument for comfortable viewing (use locking lever on side of instrument).
- Turn eyepiece counter-clockwise until it stops. (BE GENTLE!)
- Be sure prism compensation device is at 0° and 90°, or be sure no prism rings are in place.
- Place clean sheet of white paper just ahead of lens-stop, in place of lens, so it reflects light into the instrument.
- Place eye to eyepiece and slowly turn eyepiece clockwise until RETICLE is in focus (watch the “1” on the prism rings). DO NOT TWIST EYEPIECE BACK & FORTH.
- Remove piece of paper.
- Turn on lensometer.
- Turn power drum to high plus area (+10.00)
- Look into eyepiece again and turn power drum SLOWLY in the minus direction until reticle is clear and the target is in focus. Do not rock drum back and forth; just turn it until lines (or “1”) inside reticle are clear.
- When reticle is clear and target is in focus, power drum reading should be 0.00. If power drum reads 0.00, lensometer is in focus for your individual use.

If power drum is not at 0.00, try again. If you wore your glasses the first time, remove your glasses and try again.

If you repeatedly are off 1/8 diopter, compensate by correcting + or - 1/8 diopter amount for each lens checked.

Descriptions and examples of what you see in a lensometer:

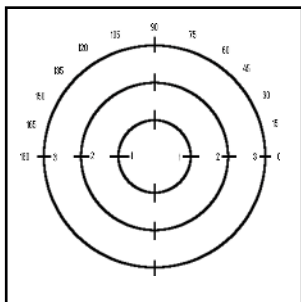

The reticle: The reticle is the series of scales on the inside of the lensometer. This scale is often composed of a series of concentric rings to denote prism and has an axis scale from 0 to 180 to allow the operator to align the prism with a line often running through 180 degrees. The reticle adjustment knob is used to turn the reticle so that the scale lines up with the prism.

The “Target”: The center of the reticle is a small circle. The circle has lines that divide it in to perfect quarters. You use the lines and the center circle to assure that you have the lens’s optical center correctly positioned in the lensometer for accurate verification (or layout) results. When the point where the sphere lines and cylinder line cross each other is perfectly centered within the circle, the lens is said to be in target. The center of the target is where you want your sphere and cylinder lines to cross when Rx does not require prism.

Prism value: Prism value rings are given in 1,2 and 3 diopters. If you could draw a straight line vertically and horizontally through the center of the target you would have a guide for UP, DOWN, IN, and OUT prism.

Axis position line: This is the line that moves when we turn the chrome knurled sleeve. It is not necessary to move it but it helps you bring a lens in target and on center at the correct axis.

*Would you like to see video lessons on using the lensmeter and lens clock? How about a step-by-step video of Standard Alignment?
Visit us at: OpticianWorks.com*

Lines: There are two sets of lines you will need to recognize. Sphere lines and cylinder lines. Sphere lines are the three thin ones, cylinder lines the three thick ones. When you look inside the lensmeter you will see one of these two images depending on where the filter lever on your lensometer is set:



Sphere Lines: Sphere lines appear in the eyepiece as three, bright, closely aligned, parallel lines. When the lensometer is in focus, and the lens or axis wheel is turned so that the lens's sphere power and axis positions are correct, the three thin sphere lines will appear as perfect straight lines.

Sphere Lines: Sphere lines appear in the eyepiece as three, bright, closely aligned, parallel lines. When the lensometer is in focus, and the lens or axis wheel is turned so that the lens's sphere power and axis positions are correct, the three thin sphere lines will appear as perfect straight lines.

Using a manual lensmeter:

Cylinder Lines: Cylinder lines appear in the eyepiece as three bright bars slightly thicker than sphere lines, and spaced a little further apart. Cylinder lines are always checked after the sphere lines are brought in to focus and the axis has been positioned so the sphere lines are closed.

The power drum is just an old-fashioned number line. It is arranged in whole numbers and fractional steps (expressed as decimals) which begin at zero and go in both positive and negative directions.

The numbers represent positive and negative diopter powers.

If you can understand a number line, you can understand a lensometer power drum.



The power drum is divided into 1/8th diopter steps, from 0.00 to +/- 3.00, and in 1/4th diopter steps, from +/- 3.00 to its highest power reading of +/- 20.00 diopters.

Always read and write numbers from the lensometer as decimals carried out to two places: +1.00, 0.00, -1.75, +0.25.

Cylinder powers are not read from the drum. They are calculated as the total amount of diopters the drum has traveled. For example, if the drum moved from +2.00 to +1.00, it traveled -1.00 diopters. This would be the case if the Rx read, "+2.00 -1.00 x 120."

Decimal to fraction equivalents:

- 0.125 = 1/8
- 0.25 = 1/4
- 0.37 = 3/8
- 0.50 = 1/2
- 0.62 = 5/8
- 0.75 = 3/4
- 0.87 = 7/8
- 1.00 = 1.00

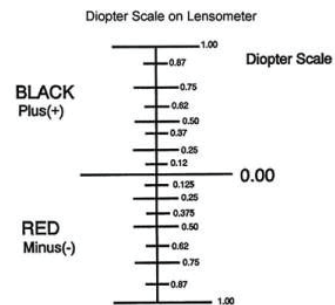

Using this drum answer the following questions: Remember for your cylinder to C-O-U-N-T the distance the drum travels not the drum!

<p>1 Axis Wheel: 45 1st Drum Reading: -3.00 2nd Drum Reading: -4.75 Rx is: _____ A: -4.75 -3.00 X 45 B: -3.00 -1.75 X 45</p>	<p>2 Axis Wheel: 78 1st Drum Reading: -0.50 2nd Drum Reading: -1.00 Rx is: _____ A: -0.50 -0.50 X 78 B: -1.00 -0.50 X 78</p>	<p>3 Axis Wheel: 126 1st Drum Reading: -3.25 2nd Drum Reading: -2.75 Rx is: _____ A: -3.25 +0.50 X 126 B: -3.25 -2.75 X 126</p>
<p>4 Axis Wheel: 158 1st Drum Reading: -4.50 2nd Drum Reading: -4.00 Rx is: _____ A: -4.00 -0.50 X 158 B: -4.50 +0.50 X 158</p>	<p>5 Axis Wheel: 180 1st Drum Reading: +1.25 2nd Drum Reading: -1.25 Rx is: _____ A: +1.25 -2.50 X 180 B: 0.00 -1.25 X 180</p>	<p>6 Axis Wheel: 52 1st Drum Reading: -1.00 2nd Drum Reading: -1.50 Rx is: _____ A: -1.00 -0.50 X 52 B: -1.00 -1.50 X 52</p>

Answers: 1:B, 2:A, 3:A, 4:B, 5:A, 6:A

Lens Clock



A lens measure, or lens clock has three points of contact which are placed on the lens surface to measure its curve(s). The outer two points are stationary while the inner point moves in or out to measure the sagittal depth of the lens.

From the sagittal depth the instrument indicator displays the curve in diopters, with plus (+) curves shown in one direction and minus (-) curves in the other.

- Convex curves are read as +
- Concave curves are read as -

The lens measure can also be used to determine whether a lens surface is spherical or toric by placing the lens measure on the optical center of a lens and rotating the instrument about the center.

- If the indicator does not move while rotating, the surface is spherical.
- If the indicator changes when the lens measure is rotated, the lens surface is toric, with the minimum and maximum readings corresponding to the primary meridians of power.

When using a lens measure, keep in mind **the instrument is calibrated to read powers of lens materials with a refractive index of 1.53**, therefore higher index materials will have a true power greater than the indicated measurement.

With a lens measure, the power cross, and the total power equation (same as the Nominal Lens Formula using F instead of D) it is possible to determine the nominal power of spherical and toric lenses.

$$F1 + F2 = F \text{ Total}$$

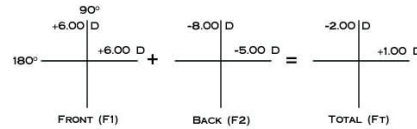
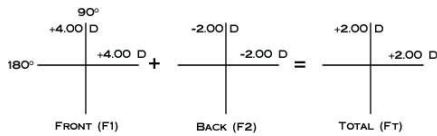









For example, if we use the lens measure to find the curve on the front surface of a lens to be +4.00 D in all meridians and the curve on the back surface of the same lens to be -2.00 D in all meridians, we know the curves are spherical and can determine the total power of the lens as follows:

Our prescription would be +2.00 Sphere

Now, if we find the curve on the front surface of the lens to be +6.00 D and determine the back surface to be toric with a measurement of -8.00 D in the 90° meridian and -5.00 in the 180° meridian our power determination would look like this:

Our prescription would be -2.00 +3.00 X 90 or +1.00 - 3.00 X 180

Tool	Name	Description
	Nylon Jaw Pliers	Common use all adjustments
	Axis Aliging Pliers	Rotating Lens
	Compression Pliers	3 - PC Mounts
	3-Piece Frame Adjusting Pliers	For adjustmen frames.
	Rx Aligner	
	Hot Air Frame Warmer	For warming plastic frames.
	Compression Sleeve Cutters	For trimming compression sleeves.
	Hex Wrenches / Screwdrivers	
	Nose Pad Pliers	For screw-on, push-on, and clip-on type nose pad assembly adjustments.

Final Jeopardy Round 5

Tools	Match
<p>It is used to warm a frame for adjustments. ____</p> <p>It is a tool that works on the Nominal Lens Formula. ____</p> <p>It might be used to correct temple fold angle. ____</p> <p>It is a plier with a protective jaw. ____</p>	<p>A What is a lens clock?</p> <p>B What is a nylon jaw plier?</p> <p>C What is a temple angling plier?</p> <p>D What is a hot air blower?</p>

Verification

These are the ANSI Standards from 2020 the last time they were updated. ANSI standards do change so be sure you check online for the correct version being used on the current exam.



QUICK REFERENCE GUIDE – ANSI Z80.1-2020

1. Tolerance on Distance Refractive Power (Single Vision, Multifocal and Power Variation Lenses with a single reference point)

Sphere Meridian Power (minus cylinder convention)	Tolerance on Sphere Meridian Power (minus cylinder convention)	Cylinder ≥ 0.00 D ≤ -2.00 D	Cylinder > -2.00 D ≤ -4.50 D	Cylinder > -4.50 D
From - 6.50 D to + 6.50 D	± 0.13 D	± 0.13 D	± 0.15 D	$\pm 4\%$
Stronger than ± 6.50 D	$\pm 2\%$	± 0.13 D	± 0.15 D	$\pm 4\%$

2. Tolerance on Distance Refractive Power (Power Variation Lenses “Progressive Addition Lenses” with more than one reference point)

Sphere Meridian Power (minus cylinder convention)	Tolerance on Sphere Meridian Power (minus cylinder convention)	Cylinder ≥ 0.00 D ≤ -2.00 D	Cylinder > -2.00 D ≤ -3.50 D	Cylinder > -3.50 D
From - 8.00 D to + 8.00 D	± 0.16 D	± 0.16 D	± 0.18 D	$\pm 5\%$
Stronger than ± 8.00 D	$\pm 2\%$	± 0.16 D	± 0.18 D	$\pm 5\%$

3. Tolerance on direction of cylinder axis

Nominal value of the cylinder power (D)	< -0.12 D	≥ -0.12 D ≤ -0.25 D	> -0.25 D ≤ -0.50 D	> -0.50 D ≤ -0.75 D	> -0.75 D ≤ -1.50 D	> -1.50 D
Tolerance of the axis (degrees)	Not Defined	$\pm 14^\circ$	$\pm 7^\circ$	$\pm 5^\circ$	$\pm 3^\circ$	$\pm 2^\circ$

4. Tolerance on addition power for multifocal and progressive addition lenses

Nominal value of addition power (D)	≤ 4.00 D	> 4.00 D
Nominal value of the tolerance on the addition power (D)	± 0.12 D	± 0.18 D

5. Tolerance on Prism Reference Point Location and Prismatic Power

The prismatic power measured at the prism reference point shall not exceed 0.33Δ or the prism reference point shall not be more than 1.0 mm away from its specified position in any direction.

6. Tolerance on Prismatic Imbalance (mounted)

Single Vision And Multifocal Lenses	Vertical	Vertical	Horizontal	Horizontal
	0.00 to $\leq \pm 3.375$ D	$> \pm 3.375$ D	0.00 to $\leq \pm 2.75$ D	$> \pm 2.75$ D
Tolerance	$\leq 0.33\Delta$	≤ 1.0 mm difference in height of PRPs	$\leq 0.67\Delta$	$\leq \pm 2.5$ mm from specified distance interpupillary distance

Copyright © 2020 by The Vision Council of America/dba The Vision Council. All rights reserved. This ANSI Z80.1-2020 Quick Reference Guide may not be reproduced without the express written permission of The Vision Council.

Progressive Addition Lenses	Vertical	Vertical	Horizontal	Horizontal
	0.00 to $\leq \pm 3.375$ D	$> \pm 3.375$ D	0.00 to $\leq \pm 3.375$ D	$> \pm 3.375$ D
Tolerance	$\leq 0.33\Delta$	≤ 1.0 mm difference in height of PRPs	$\leq 0.67\Delta$	≤ 1.0 mm from specified monocular interpupillary distance

7. Base Curve Tolerance

When specified, the base curve shall be supplied within ± 0.75 D.

8. Center Thickness Tolerance

The center thickness shall be measured at the prism reference point of the convex surface. It shall not deviate from the nominal value by more than ± 0.3 mm.

9. Segment Size & Tilt Tolerance for Multifocals

The segment dimensions (width, depth, and intermediate depth) shall not deviate from the nominal value by more than ± 0.5 mm. The difference between the segment dimensions (width, depth, and intermediate depth) in the mounted pair shall not exceed 0.5 mm unless specified.

The segment tilt for each lens shall be within $\pm 2^\circ$ as measured from the 180° .

10. Segment Vertical Location, Tilt and Fitting Cross Vertical Location

Multifocals: the segment height for each lens shall be within ± 1.0 mm. The difference between the segment height in the mounted pair shall not exceed 1.0 mm.

Progressives: the fitting cross height for each lens shall be within ± 1.0 mm. The difference between the fitting cross height in the mounted pair shall not exceed 1.0 mm.

The horizontal axis tilt for each lens shall be within $\pm 2^\circ$ using the permanent horizontal reference markings.

11. Segment Horizontal Location and Fitting Cross Horizontal Location

Multifocal lenses: the distance between geometric centers of the segments in the mounted pair shall be within ± 2.5 mm of the specified near interpupillary distance. The inset in both lenses shall appear symmetrical and balanced unless monocular insets are specified.

Progressive addition lenses: the near reference point is set by the lens design. The fitting cross location in progressive lenses shall be within ± 1.0 mm of the specified monocular interpupillary distance for that lens.

12. Localized Errors

Localized power errors or aberrations caused by waves, warpage or internal defects, which are detected by visual inspection, are permissible if no measurable or gross focimeter target element distortion or blur is found when the localized area is examined with a focimeter. Areas outside a 30 mm diameter from the distance reference point, or within 6 mm from the edge, need not be tested for local power errors or aberrations. Progressive addition lenses are exempt from this requirement.

13. Prescription Impact-resistant Dress Eyewear Lenses

All lenses must conform to the impact resistance requirements of [Title 21, Code of Federal Regulations, 801.410 \(CFR 801.410\)](#).

14. Axis of Polarization

If there is a marking on the spectacle lens indicating the intended direction of horizontal orientation of polarization, then the actual plane of transmittance shall be at $90 \pm 3^\circ$ from this marking.

Copyright© 2020 by The Vision Council of America/dba The Vision Council. All rights reserved.
This ANSI Z80.1-2020 Quick Reference Guide may not be reproduced without the express written permission of The Vision Council.

Verification of single vision lenses:

- Always start with right lens first.
 - Draw back lens holder and place glasses facing you, with right lens against lens stop. Aim to be as close to lens center as possible.
 - Gently release lens holder so it holds the lens against lens stop. Check to be sure glasses are sitting level, and that both eyewires are touching spectacle table.
- Look at sphere power called for in prescription. Set your power drum to correct number. Be sure you are in red for minus or black for plus, and that you are at correct position on the number line.

Look at axis called for in prescription and set axis wheel to correct number.

Note: A spherical lens will not have a cylinder value or axis. You may set axis wheel at any number and it will not matter.

Look inside lensometer and move lens so the target is in the center of reticle.

- If lens is a sphere, you should see both sphere lines and cylinder lines in perfect focus.
- If lens is a sphero-cylinder, you should only see the three thin sphere lines in focus.
- If you have focus, the lens was made correctly for sphere power.

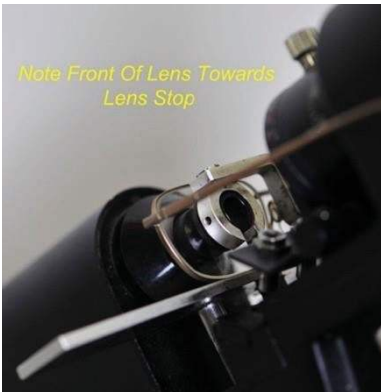

Determining cylinder power:

- Assuming sphere and axis are correct, and the lens is a sphero-cylinder, look at the cylinder sign and cylinder power.
- Turn power drum in appropriate direction until three thick cylinder lines are in focus
- If cylinder sign is minus, turn the power drum away from you in a more minus direction to get cylinder lines in focus.
- If cylinder sign is plus, turn the power drum towards you in a more plus direction to get cylinder lines in focus.
- Now **(here is the tricky part)** count, c-o-u-n-t, the amount traveled from start to finish. Do not read the power drum! Count the distance traveled. The difference will be the cylinder amount. It should match what is written on the prescription. If it does not, then rock the drum back and forth until the cylinder lines are in focus. Count how far off the power is, and check your tolerance.
- Using the marking device, dip the pins in the inking pad and then “dot” the lens to mark the lens’s optical center. The center dot represents the lens’s OC, and will be used to verify the patient’s pupillary distance. The outer dots allow you to visualize the lens placement within the eyewire opening and to check for vertical imbalance.
- Without moving the spectacle table, repeat process for left lens.

Verification of lined-style multifocal lens powers:

Follow all the steps outlined above for verification of single vision lenses and then perform the following steps to verify the bifocal add power.

- Place glasses in lensometer facing away from you (in opposite direction from what you do in all other cases) at the OC mark for distance portion of lens.
- Set the power drum to sphere power required in prescription.
- Look in lensometer and turn axis wheel to get closed sphere lines (do not pay attention to axis marked on prescription).
- Now bring addition segment up to lens stop, trying to center segment as you do a lens.
- Look in lensometer and turn power drum towards you in the plus direction until you see sphere lines come into focus.
- The distance the drum traveled from original sphere power to where it is now should match the add power as noted on prescription +/- or tolerance.

Example: If I have a sphere power of -2.00, and when I move my segment up to the lens stop, I find my sphere lines come in to focus at -1.00, then my add power is a +1.00. That should match the power indicated on my prescription.

Verification of progressive lenses:

The fitting cross is NOT used during verification.

The lens near or add power is read off the permanent etched lens markings not in the lensmaster.

The Rx is checked by placing the lens Distance Circle in the lensometer centered against the lens stop.

If the target in the lensometer is not centered, you may use a Prism Ring or the Prism Compensation Device to center it and read the lens power(s).

Once you have the lens in the proper position you can read the Rx as you would for single vision.

Vertical Imbalance:

What you want to see in the lensmeter during verification when switching from the right lens to the left lens WITHOUT moving the spectacle table is that the targets are both in the exact same position vertically between both eyes.

Vertical imbalance occurs when the right lens OC is not on the same plane as the left lens OC. Vertical imbalance is checked by moving from the right lens to the left lens while leaving the spectacle table at the same height. If the OC target is displaced from the center of the reticle when you switch from right to left, the pair has vertical imbalance.

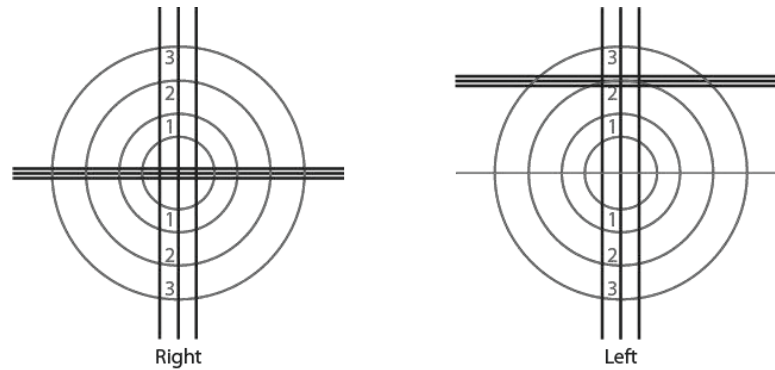

2Δ vertical imbalance between right and left lens.

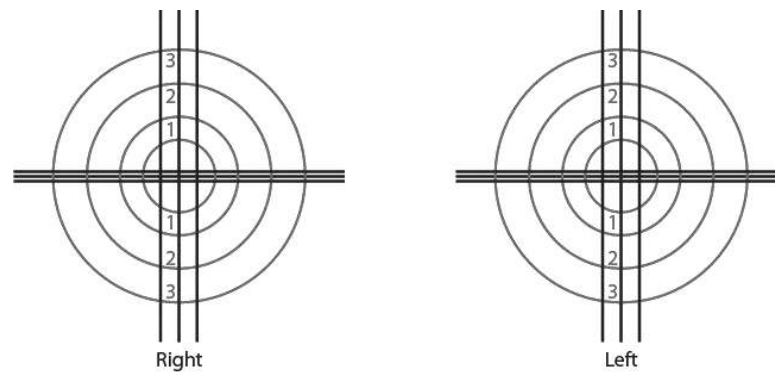

No vertical imbalance between right and left lens.

Vertical imbalance is checked by starting with the strongest lens being placed in the lensometer first. Write down the right and left prescriptions, and then do flat transposition for each. Determine the lens with the strongest power.

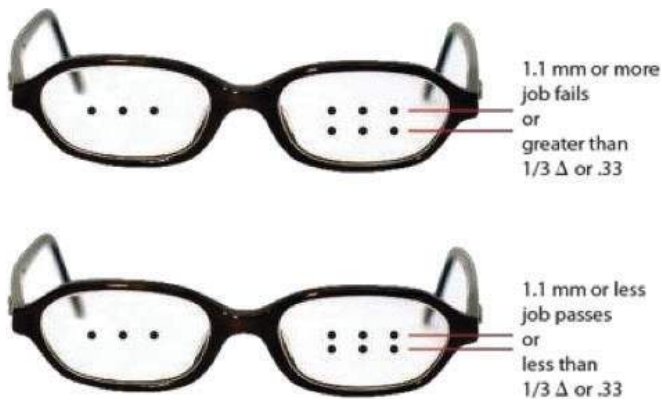

Verifying Prescribed Prism

Prism is measured from where the patient looks through the lens! If you mark the patient PD on the lens and place it in the lensometer with the mark centered in the lens stop What You See Is What You Get (WYSIWYG).

To check that prism is correct as prescribed in single vision lenses, mark the patient PD monocularly using a layout chart.

Mark the patient PD at half the B measurement. Place the lens in the lensometer exactly on the dot, and read the lensometer prism scale on the reticle. The lensometer target should be at the corresponding number in the lensometer and in the position noted.

Note: If an OC height was given then you would mark the PD at the height specified.

Prism in progressive lenses is measured at the prism dot below the fitting cross. To check that prism is correct as prescribed in progressive lenses, use the temporary markings or re-mark the lens using a layout chart and include the dot below the distance circle (see image in first section).

- If the difference is 1 mm or less, the lens will pass.

You will probably have a question about this on the ABO.

- Dot the OC of the lens with the strongest power.
- Now move to the other lens, without moving the spectacle table, and dot that lens exactly where it falls.
- Now move the spectacle table and find and dot the OC in that lens.
- Measure the distance between the first set of dots and the second set of dots.

If it is greater than 1mm, see the standards and determine if lenses need to be remade.

Can you match the image with the concept?

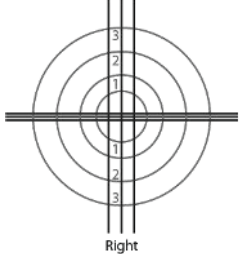
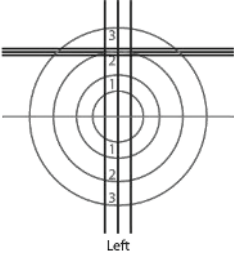
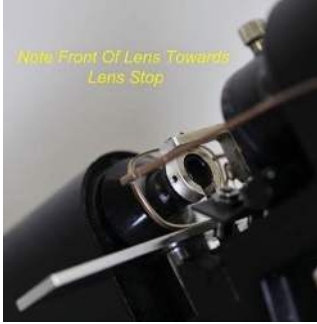
Verification	Match
<div style="display: flex; justify-content: space-around;"> <div style="text-align: center;">  <p>Right</p> </div> <div style="text-align: center;">  <p>Left</p> </div> </div> <p style="text-align: center; font-size: 2em; font-weight: bold;">A</p>	<div style="text-align: center;">  <p style="color: yellow; font-size: 0.8em;">Note Front Of Lens Towards Lens Stop</p> </div> <p style="text-align: center; font-size: 2em; font-weight: bold;">B</p>

Chapter 8: Regulations & Standards

Regulatory Agencies:

ASTM – The American Society for Testing Materials sets standards for sports-related products. Standard F803 sets standards for safety eyewear used in sports.

ANSI – The American National Standards Institute is a private agency whose purpose is to set commercial and industrial standards. Standard Z80.1 sets standard Recommendations for Prescription Ophthalmic Lenses.

OSHA – The Occupational Safety and Health Administration is a federal government agency established for the purpose of reducing deaths, injury, and illnesses in the workplace.

FDA – The Food and Drug Administration is a federal government agency whose function is to enforce laws related to the production and labeling of food, drugs, and cosmetics. Contact lenses and eyeglasses are considered medical devices and fall under the jurisdiction of the FDA.

Standards Publications of Interest to Opticians:

The **Z80.1** standard serves as a guideline for both dispensers and optical laboratories to follow prior to the delivery of finished eyewear to the patient. It applies to the processing of all prescription ophthalmic spectacle lenses in edged or assembled form. Relevant optical specifications and tolerances of this standard also apply to uncut lenses supplied by an optical laboratory to be used in filling a specific prescription.

Source: The Vision Council

ANSI Z80.1 - 2020	Ophthalmics - Prescription Ophthalmic Lenses - Recommendations
ANSI Z80.3 - 2018	Ophthalmics - Non-Prescription Sunglasses and Fashion Eyewear - Requirements
ANSI Z80.25 - 1996	Ophthalmics - Instruments: Fundamental Requirements and Test Methods
ANSI Z87.1 - 2020	Occupational and Educational Personal Eye and Face Protection

Impact Resistance Testing:

The FDA requires all ophthalmic glass lenses be individually tested for impact resistance according to 21CFR801.410.

In the impact test, a 5/8-inch steel ball weighing approximately 0.56 ounce is dropped from a height of 50 inches upon the horizontal upper surface of the lens. The ball shall strike within a 5/8-inch diameter circle located at the geometric center of the lens. The ball may be guided but not restricted in its fall by being dropped through a tube extending to within approximately 4 inches of the lens.

To pass the test, the lens must not fracture.

With the following exemptions: Prism segment multifocal, slab-off prism, lenticular cataract, iseikonic, depressed segment one-piece multifocal, biconcave, myodisc and minus lenticular, custom laminate and cemented assembly lenses shall be impact resistant but need not be subjected to impact testing.

Liability and Duty to Warn:

In 1987 the OLA (Optical Laboratories Association) reminded offices about their duty to warn patients about the impact resistance of various lens materials. The dispensing optician has a legal responsibility or liability for the products, services, and information they provide to the public. The term "Duty to Warn" has been used in our industry to inform the patient of the safety aspects of polycarbonate or Trivex lenses compared to other lenses. This duty to warn covers the professional of negligence torts involving injury resulting from broken lenses or eyewear. If the optician has knowledge of a product better suited to the safety requirements of a customer, it is his/her duty to warn the patient so they can make an informed decision.

Safety Lenses

Safety lenses, or industrial lenses, fall into two primary categories: Basic and High Impact. These categories are defined by the American National Standards Institute (ANSI) and have been adopted by the Occupational Safety and Health Administration (OSHA).

ANSI Z87.1-2003

Basic Rx impact lenses:

- Shall be 3.00mm thick except those over +3.00D or greater shall have a minimum thickness of 2.5
- Pass a drop ball test of a 1-inch diameter steel ball dropped 50 inches
- Be sandblasted with the manufacturer's identification
- Be delivered to the wearer bearing a Warning Label indicating that the protector only meets the Basic Impact Standard

High impact Rx lenses:

- Shall not be less than 2.0mm thick at their thinnest point.
- Pass a high velocity test in which a ¼ inch steel ball is shot at a lens at 150 ft/second
- Be sandblasted with the manufacturer's identification and a plus (+) sign
- Be manufactured from either polycarbonate or Trivex

Whether they are basic or high impact resistant lenses they will be placed in a frame marked with the Z87+ mark on the frame front and temple.

Last one!	
Standards	Match
The agency behind the standards we use _____	A OSHA
The Z code for ophthalmic products _____	B Z87
The test used for impact resistance _____	C ANSI
The Z code for safety glasses _____	D Z80.X
The agency for workplace safety _____	E Drop ball

Don't Stop Now!
You have so much more to learn.

Working With Insurance – Practice Management Tips– Lens Finishing – Repairs – All About Contact Lenses – Step-By-Step Prism Problems & More

*The more you learn the more fun your job will be.
Join us at: OpticianWorks.com*

Appendix

DOCUMENT SPONSORS AND CONTRIBUTING AUTHORS (2010)

Laramy-K Optical 800.525.1274
www.laramyk.com

John Seegers, OpticianWorks.com

Harry Chilinguerian, ABO-AC, NCLE-AC

Gary McArrell, ABOM

George Karber, ABOC

Bob Faktor, ABOC

Bob Fesmire, ABOC

Carrie Wilson, ABO-AC, NCLEC

William MacGillivray

Keith Benjamin

Martin Goergen HMC, USNRet

Criteria for exam as set by the American Board of Opticianry website 2022

Note: This criteria is based on the role of the optician from 30 and 40 years ago. The ABO is the single greatest threat to the role of the optician. The exam tests for the wrong things in the wrong way. Do not rely on the ABO to prepare you for the job of optician in the world today.



National Opticianry Competency Examination (NOCE) Basic Test Specifications (100 questions)

Domain I. Ophthalmic Optics (25 questions)

1. Terminology
2. Prescriptions
 1. Format and content of prescription
 2. Relationship between prescription measurements and finished product
 3. Transposition of a prescription
 4. Common prescription irregularities (e.g., missing signs, opposite signs, incomplete notation)
3. Lens characteristics (e.g., centration, optical centers, major reference points, base curves, thickness, absorption, index of refraction, magnification, reflection, dispersion, impact resistance, abbe value)
4. Lens powers (e.g., plus, minus, spherical, compound, prism)
5. Lens types (i.e., single vision, multifocals)
6. Various lens materials (e.g., low index, mid index, high index, ultra-high index)
7. Effect of changes in base curve and thickness
8. Calculating prismatic effects
9. Effect of lens materials and design on thickness, weight, and dispersion (e.g., aspheric, digital surfacing)
10. Measurement systems and conversions (e.g., Imperial, metric, box)
11. Lens options for various occupations and other lifestyle activities
12. Usable accommodation and the range of vision with various lens powers
13. Neutralization of lenses



14. Ophthalmic Formulas

1. Prentice's rule
2. Vertical imbalance
3. Vertex compensation
4. Centration (e.g., horizontal and vertical)
5. Power in oblique meridians
6. Magnification/minification
7. Anisometropia/antimetropia
8. Aniseikonia

Domain II. Ocular Anatomy, Physiology, Pathology, and Refraction (10 questions)

1. Structure of the Eye and Function

1. Anterior Adnexa
 - a. Eyelids
 - b. Muscles
 - c. Lacrimal apparatus
2. Anterior Segment
 - a. Sclera
 - b. Cornea
 - c. Iris
 - d. Pupil
 - e. Aqueous humor
3. Posterior Segment
 - a. Lens
 - b. Ciliary body
 - c. Vitreous humor
 - d. Retina
 - e. Fovea/macula
 - f. Rods and cones
 - g. Optic nerve
 - h. Visual pathway

2. Pathology

1. Facial configurations (anomalies)
2. Glaucoma (intraocular pressure)
3. Macular degeneration
4. Scotoma
5. Cataracts
6. Diabetes
7. Amblyopia
8. Pseudophakia and aphakia



9. Nystagmus

10. Strabismus

3. Refraction

1. Refractive Errors

- a. Visual acuity
- b. Myopia
- c. Hyperopia
- d. Presbyopia
- e. Astigmatism (simple and compound)

2. Prism Imbalance

- a. Muscle imbalance
- b. Diplopia
- c. Phorias and tropias (e.g., cover/uncover test)
- d. Convergence / divergence

Domain III. Ophthalmic Products (20 questions)

1. Frames

- 1. Availability (e.g., colors and sizes, wrap, materials)
- 2. Uses, limitations, and liabilities
- 3. Frame parameters

2. Lenses

- 1. Availability (e.g., base curves, segment styles and sizes, materials, tints, coatings, polarization, edge treatments and other special processes)
- 2. Uses, limitations, and liabilities (e.g., traditional and digitally designed lenses)
- 3. Lens parameters

3. Low Vision Aids

4. Preassembled eyewear (i.e., over the counter eyewear)

Domain IV. Instrumentation (15 questions)

1. Use of lens power measuring devices (e.g., focimeter, lensmeter)

2. Use of Lens Measurement Devices

- 1. Lens clock
- 2. Calipers
- 3. Millimeter ruler
- 4. Circumference gauge

3. Dispensing Instrumentation



1. Corneal reflex pupilometer
2. Distometer
3. Hand tools used to adjust eyewear (e.g., pad pliers, angling pliers, etc.)
4. Digital measurement system

Domain V. Dispensing Procedures (20 questions)

1. Patient History
 1. Lifestyle visual needs and wants of patient
 2. Cosmetic/pathological/therapeutic needs of patient
 3. The effect of the patient's physical characteristics on frame and lens performance
2. Fitting, Adjusting, and Measuring
 1. Fitting or adjusting of frames (e.g., size, vertex distance, pantoscopic tilt)
 2. Proper positioning of multifocals, optical centers, and major reference points
 3. Differences between new and previous eyewear that may create visual problems (e.g., lens type, enhancements, power, axis)
 4. Frame measurements (e.g., eyesize, bridge size, temple length, distance between lenses and effective diameter).
 5. Frame alignment and the fitting triangle
 6. Properties and handling of frame materials
 7. Procedures used to adjust eyewear (e.g. facial structure, facial asymmetry, weight distribution and pressure)
 8. The optical effects of pantoscopic/retroscopic tilt, face form, and vertex distance
 9. Lens parameters (e.g., circumference, blank size, centration, distance between centers, major reference points)
 10. Coordination of eye and head movements
 11. The effects of changes in lens power, design, and material (e.g., visual field limitations, peripheral distortions, customer/patient orientation)

Domain VI. Laws, Regulations, and Standards (10 questions)

1. Product performance and limitations (e.g., "duty to warn" requirements, UV, HEV, ASTM)
2. Applicable national guidelines, laws, regulations, and standards (e.g., OSHA, ANSI, FDA, EPA, HIPAA)
3. Universal precautions (e.g., health and safety issues)
4. Coding (CPT), EMR (electronic medical records), and related insurance requirements